



*An Online CPD Course
brought to you by
CEDengineering.ca*

Introduction to Welding and Non-Destructive Testing (NDT)

Course No: T06-005
Credit: 6 PDH

Anuj Bhatia



Continuing Education and Development, Inc.

P: (877) 322-5800
info@cedengineering.ca

TABLE OF CONTENTS

1 CHAPTER -1: CHARACTERISTICS OF MATERIALS 6

1.1 Material Properties 7

1.2 Twenty Things a Welder Need to Know 9

1.3 Common Welding Metals 10

1.4 Alloying Elements in Steel..... 12

1.5 Hot Rolled Steel V/s Cold Rolled Steel 18

2 CHAPTER - 2: WELD JOINTS 20

2.1 Basic Joints..... 20

2.2 Joint Preparations 23

2.3 Faying Surface and Weld Seams..... 23

2.4 Principles of Joint preparation 24

3 CHAPTER -3 WELDING SYMBOLS 32

3.1 Weld symbol vs Welding symbol..... 32

3.2 Welding Symbols 34

3.3 Interpreting Welding Symbols 36

3.4 Difference between AWS and ISO Symbols 44

3.5 Practice Examples 46

4 CHAPTER - 4: TECHNOLOGY OF WELDING PROCESSES..... 50

4.1 Shielded Metal Arc Welding (SMAW)..... 50

4.2 Submerged Arc Welding (SAW)..... 51

4.3 Flux-Cored Arc Welding (FCAW) 52

4.4 Gas Metal Arc Welding (GMAW)..... 53

4.5 Gas Tungsten Arc Welding (TIG)..... 55

4.6 Types of Welding Operations..... 56

5 CHAPTER - 5 WELDING DEFECTS AND DISCONTINUITIES 57

5.1 Classification of Defects 58

5.2 Cracks 59

5.3 Porosity 61

5.4 Undercut 62

5.5 Underfill 63

5.6 Incomplete Penetration 63

5.7	Lack of Fusion (Incomplete Fusion)	65
5.8	Spatters.....	66
5.9	Overlap	67
5.10	Excessive Penetration.....	67
5.11	Inclusion.....	67
5.12	Wagon Tracks.....	68
5.13	Warpage	69
5.14	Burn Through	69
6	CHAPTER - 6 WELD QUALITY CONTROL AND WPS.....	71
6.1	Welding Quality Objectives	71
6.2	Importance of Weld Design	71
6.3	Characteristics of a Good Weld.....	71
6.4	Codes and Standards	72
6.5	Weld Quality Control and Inspection	74
6.6	Welding Procedure Specification (WPS).....	75
6.7	Some Other Relevant Terminology	79
7	CHAPTER -7 WELD INSPECTION AND TESTING	83
7.1	Weld Properties.....	83
7.2	Testing and Inspection Methods	83
7.3	Destructive Testing	83
7.4	Macro Etch Testing	84
7.5	Fracture Test.....	84
7.6	Toughness Test	85
7.7	Transverse Tensile Test.....	86
7.8	Bend Test.....	90
7.9	Hardness Test.....	92
8	CHAPTER - 8 NON-DESTRUCTIVE TESTING (NDT).....	93
8.1	Types of Non-destructive Tests (NDT).....	93
8.2	Visual Testing (VT).....	94
8.3	Liquid Penetrant Testing (PT)	97
8.4	Magnetic Particle Testing (MT)	101
8.5	Radiographic Testing and Digital Radiography (RT/DR).....	106

8.6	Ultrasonic Testing (UT)	109
8.7	Electromagnetic or Eddy current testing (ET).....	112
8.8	Comparison of different NDT methods.....	115
8.9	Applications of NDT	117
9	CHAPTER – 9 ACCEPTANCE CRITERIA FOR WELD DEFECTS.....	121
9.1	Acceptance criteria for Visual Inspection	121
9.2	Acceptance criteria for Radiography Test (RT)	122
9.3	Acceptance criteria for Ultrasonic Test (UT)	123
9.4	Acceptance criteria for Liquid Penetrant Test	124
9.5	Acceptance criteria for Magnetic Particle Test (MT).....	124
10	Annexure -1: Codes and Standards.....	127

TABLE OF FIGURES AND TABLES

Figure 1.Weld Zone Terminology.....	6
Figure 2. Stresses in welded joints created by Tensile, Compression, Bending, Torsion, Shear Forces ..	20
Figure 3.Types of Joints.....	21
Figure 4.Butt Joint	21
Figure 5.Tee Joint	22
Figure 6.Corner Joints.....	22
Figure 7.Lap Joints.....	23
Figure 8.Edge Joints	23
Figure 9.Dimensions and Properties of Weld Seams	24
Figure 10.V-Groove.....	25
Figure 11.U-Groove	26
Figure 12.Types of Grooves.....	26
Figure 13.Corner Joints Edge Preparations.....	28
Figure 14.Edge Joints-Edge Preparations	28
Figure 15.Lap Joints Edge Preparation	29
Figure 16.Tee Joint Edge Preparations	29
Figure 17.Groove Weld Positions	30
Figure 18.Fillet Weld Positions.....	30
Figure 19.Groove Angle	31
Figure 20.Welding Symbol vs Weld Symbol	33
Figure 21.Basic Weld Symbol.....	33
Figure 22.Basic Weld Symbols	34
Figure 23.Basic Welding Symbols and Their Location Significance.....	34
Figure 24.Basic Groove Symbols	34
Figure 25.Basic Welding Groove Symbols	35
Figure 26.Supplementary Symbols.....	35
Figure 27.Weld Orientation	36
Figure 28.Weld Location	37
Figure 29.Weld Symbol on Bottom Side	37
Figure 30.Weld Symbol on Top Side	38

Figure 31.Weld Symbol on Bottom and Top Side	38
Figure 32.Weld Symbol on Bottom and Top Side for two Sides.....	38
Figure 33.Weld All-round Symbol	39
Figure 34.The Use of Weld All-Around Symbol	39
Figure 35.Field-weld Symbol.....	39
Figure 36.Weld Seam	40
Figure 37.Length and Width Symbol for Weld Seam.....	41
Figure 38.1/4-inch fillet weld with a length of 3 placed on the arrow side	41
Figure 39.Intermittent Fillet Welds	41
Figure 40.Intermittent weld with 1/2-inch weld thickness, weld length of 8 inch and a pitch of 12 inch	42
Figure 41.Intermittent weld (both sides) with 1/8-inch weld thickness, weld length of 5 inch and a pitch of 10 inch.....	42
Figure 42.Staggered Welds	42
Figure 43.Multiple Arrows in Single Symbol	43
Figure 44.multiple-reference-line welding symbol	43
Figure 45.Tails Symbols.....	44
Figure 46.ISO Symbol.....	44
Figure 47.AWS Symbol.....	45
Figure 48.AWS.....	45
Figure 49.ISO.....	45
Figure 50.Welding on Both Sides (AWS and ISO)	46
Figure 51.Consolidated Welding Symbol.....	49
Figure 52.Shielded Metal Arc Welding (Stick)	51
Figure 53.Submerged Arc Welding (Sub-Arc)	52
Figure 54.Flux-Cored Arc Welding (Flux-Cored)	53
Figure 55.Gas Metal Arc Welding (MIG).....	55
Figure 56.Gas Tungsten Arc Welding (TIG)	56
Figure 57.Crack.....	59
Figure 58.Hot Cracks	60
Figure 59.Porosity	62
Figure 60.Undercut	63
Figure 61.Incomplete Penetration.....	64
Figure 62.Lack of Fusion.....	65
Figure 63.Spatters.....	66
Figure 64.Overlap	67
Figure 65.Inclusion.....	68
Figure 66.Warpage	69
Figure 67.Hole caused by Burn Through.....	69
Figure 68.Burn Through.....	70
Figure 69.Basic information about welding procedure.....	75
Figure 70.Details of Joint Design	76
Figure 71.Information about the base and filler metals to be used in the welding procedure	77
Figure 72.Information about pre and post weld heat treatment required, gas used and the positions in which the procedure will be performed	77
Figure 73.Electrical Characteristics and Technique of the Welding Procedure.....	79
Figure 74.Charpy V-notch	86
Figure 75.Tensile Testing.....	87
Figure 76.Gauge Length	88
Figure 77.Ultimate tensile strength	89
Figure 78.Weld Test Plate.....	90
Figure 79.Roller Bend Test	91
Figure 80.Free Bend Test	91

Figure 81. Visual Inspection Optical Aids	95
Figure 82. Borescope	96
Figure 83. Liquid Penetrant Testing	98
Figure 84. Liquid penetrant testing for a fluorescent inspection	99
Figure 85. Penetrant Testing Application	100
Figure 86. Illustration of Dye Penetrant Testing	100
Figure 87. Magnetic Particle Testing of a Pipeline	102
Figure 88. Indirect Induction	104
Figure 89. Illustration of Magnetic Partical Testing	104
Figure 90. Electrical Coils	105
Figure 91. Radiography	108
Figure 92. Ultrasonic Flaw Detection	110
Figure 93. Ultrasonic Testing of a Pipeline	111
Figure 94. Coil with Single Winding	113
Figure 95. Eddy Current Testing Equipment	114
Figure 96. Detect Form	119
Table 1. Carbon Content in Steel	11
Table 2. Summary Table	19
Table 3. Summary of the most frequently used NDT methods	117
Table 4. Common Applications of the NDT	119
Table 5. Volumetric flaws VS Planar flaws	120
Table 6. Nominal Thickness and maximum allowable reinforcement of a material	122

1 CHAPTER -1: CHARACTERISTICS OF MATERIALS

Welding is the process of uniting two metal parts by melting the materials at their interface and usually a filler material is added to form a pool of molten material (the weld pool) that solidifies to become a strong joint. The parts being joined are referred to as base metal and the filler is referred to as weld metal.

A welded joint made by fusion welding exhibits a fusion zone containing the weld metal, a heat affected zone (HAZ), and a zone where the properties of the base metal remain unchanged. The HAZ is not melted but the properties are altered by the welding process. The quality of weld is highly dependent on several factors, such as the nature of the base metals, the weld metal used to join them, and the heat input of the welding process used.

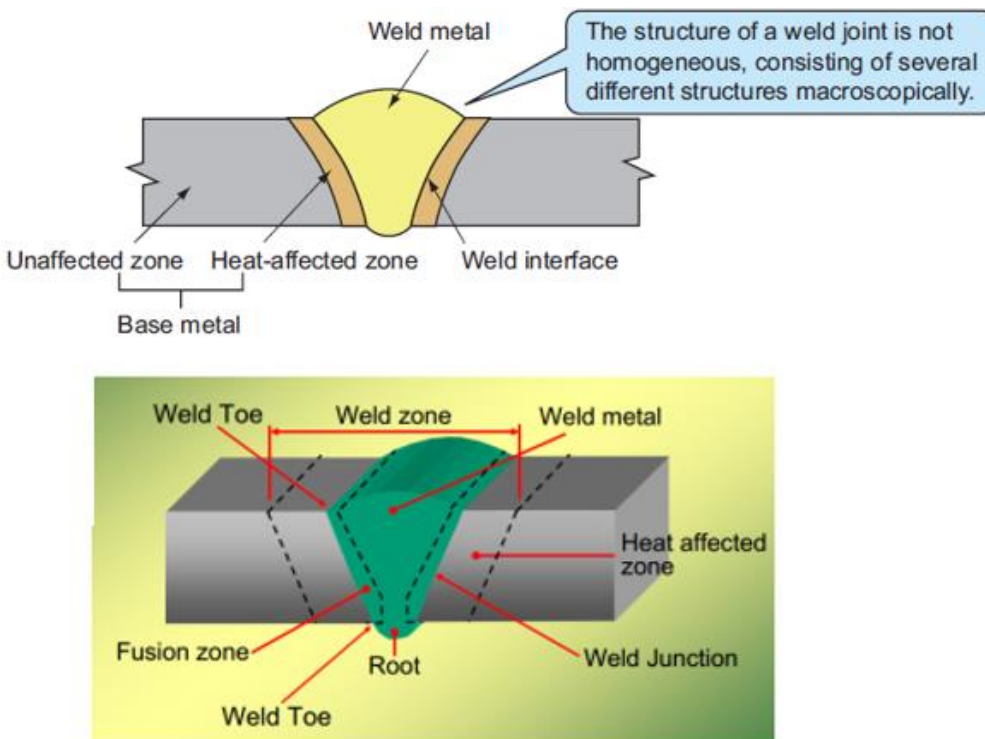

Figure 1. Weld Zone Terminology

In most cases, problems arise when the heat input is too low or too high. Heat input that is too high, either through excessive voltage, excessive amperage, or slow travel speed, can slow your solidification rate, promoting grain growth in the weld metal and HAZ. This excessive grain growth shows up in changed mechanical properties, mainly a decrease

in the material's cold weather toughness. As a rule, when the weld is made correctly, with the proper filler metal and with controlled welding parameters, it should meet or exceed the strength of the base material.

1.1 Material Properties

Each metal and metal alloy contains certain physical properties that can be altered or changed when welding occurs. Understanding what these properties are and how they may change will help us adjust our process when we encounter problems. While each material has many different physical properties that can change because of welding, we will focus on the ones that are most affected.

1.1.1 Strength

A metal's ability to resist deformation is known as its strength. Strength is quantified in four ways:

- a. Tensile Strength: A metal's ability to resist forces attempting to pull it apart.
- b. Compressive Strength: The capability of a metal to withstand being crushed.
- c. Shear Strength: The capacity of a metal to tolerate forces trying to slice or cut it apart.
- d. Torsional strength: The ability of a metal to resist forces attempting to twist it.

Strength can be altered drastically by welding.

If the weld is made with too little heat, little penetration will occur. If the weld is made with too much heat, we could ruin the chemistry of the base material. Welding can have a significant impact on a metal that has previously been heat treated. If the weld is done correctly and with the right filler metal, it should match or exceed the strength of the base material. The amount of heat the material sees will depend upon the welding process selected. For example, Gas Tungsten Arc Welding or TIG tends to put more heat into the material than a Gas Metal Arc Welding or MIG type process for the same size weld.

1.1.2 Ductility

Ductility is the capability of a metal to be permanently bent, twisted, stretched, or otherwise deformed without breaking or cracking. Ductility is also linked to the material's strength. In general, for the same cross section, a stronger material will be more rigid than

a weaker material. Adding a weld that cools quickly can reduce the ductility of some materials. On the other hand, many welds on a part that gets it really hot and keeps it hot for a sufficient amount of time can cause softening in the weld zone, especially something that had previously heat treated to increase strength or hardness.

Any weld seam that will be bent or formed at a later stage requires special attention. For the same size weld, Gas Tungsten Arc Welding (TIG) tends to put more heat into the material than Gas Metal Arc Welding (GMAW) or Shielded Metal Arc Welding (SMAW).

1.1.3 Hardness

Hardness is the resistance of being scratched or indented by another material. Welding has a significant impact on the metal's hardness. If the metal was heat-treated to increase hardness prior to welding, the material becomes softer in general and loses the heat treatment in the weld heat affected zone. Some alloys harden in the weld zone after welding and require a heat-treating technique to anneal, stress alleviate, or normalize the base material. Because a hard metal is typically a strong metal, anything that affects its hardness will also impact its strength.

1.1.4 Brittleness

Brittleness is the likelihood that a material will fail or fracture under a relatively small shock, force, or impact. Hardness and brittleness have a direct relationship as a metal's hardness is increased so does its brittleness. A brittle material cracks in a way that it could be put back together without any deformation.

1.1.5 Toughness

Toughness is the ability of a metal to absorb energy without breaking, often when subjected to an impact load. In the event that a crack occurs, or if additional stress risers such as undercut, overlap, or incomplete penetration are overlooked during inspection, an excellent fracture toughness is desired.

The welding process can significantly change the toughness of a base metal. A thorough understanding of the toughness of the base metal, weld metal and heat affected zone allow inspectors and engineers to determine if a crack on a structure, for example, a bridge needs to be repaired or if it can be left alone for some time. Because of this, codes

such as the AWS D1.5 require CVN (Charpy v-notch) testing of welding procedures. CVN testing provides values for toughness.

1.1.6 Corrosion Resistance

Corrosion resistance can be affected greatly by welding. Stainless Steels are a great example for how welding can impact corrosion resistance. If we overheat Stainless Steel when welding, the alloy elements will separate and form carbide precipitation or what some people call sugaring. Stainless becomes sensitized between about 800-1600 degrees Fahrenheit when the chromium combines with carbon to precipitate out in the form of black badness on the back side of our weld, and heat affected area.

1.2 Twenty Things a Welder Need to Know

It's important to get some basic knowledge of the mechanical properties of metals prior to welding training. This knowledge can allow a welder and inspector to determine the range of usefulness of a metal and the service that can be expected from it. It can also enable a welder to construct a safe, sound structure that meets engineering specifications.

1. The ability of a material to withstand a load pulling it apart is called its tensile strength.
2. The ability of a material to be stretched out without breaking is called ductility.
3. An Izod impact machine is used to give indication of the toughness of a material.
4. The ability to withstand indentation is called hardness.
5. Lack of ductility is called brittleness.
6. The property of a metal to return to its original shape is called elasticity.
7. Increase in carbon content causes an increase in strength and hardness.
8. When carbon percentage increases, there is a decrease in ductility.
9. Low carbon steel contains less than 0.2% carbon.
10. Low ductility in a weld metal could result in cracking.
11. Alloying is used to increase mechanical and physical properties of a steel.
12. Sulphur and phosphorus are not alloying elements; they are contamination/impurities.

13. Alloying allows designers to use smaller / thin sections and still have the same strength.
14. An alloy that contains a high percentage of chromium and nickel would have resistance to corrosion.
15. Quenching a carbon or low alloy steel will result in an increase in hardness and a decrease in ductility.
16. The hard constituent that results when steel is quenched is called martensite.
17. The tough laminated structure that is formed on slow cooling of ferrite and iron carbide (cementite) is called pearlite.
18. The amount of martensite formed depends on the speed of cooling and the percentage of carbon.
19. After quenching, the structure may be improved by reheating to 200-300°C (550-650). This is called tempering.
20. Small percentages of chromium will increase the strength and hardness, while a small percentage of nickel will increase toughness.

1.3 Common Welding Metals

1.3.1 Steel

Steel is versatile and can be used with any welding process. It is an alloy that contains iron and 2% of other elements. According to the American Iron and Steel Institute (AISI), steel can be broadly categorized into four groups based on their chemical compositions:

- a. Carbon Steels
- b. Alloy Steels
- c. Stainless Steels
- d. Tool Steels

1.3.1.1 Carbon Steels

Steels are generally classified according to carbon and alloy content.

Carbon Steel Type	% Carbon
Low Carbon Steel	0.04 – 0.15%

Carbon Steel Type	% Carbon
Mild Steel	0.15 to 0.30
Medium Carbon Steel	0.3 – 0.6%
High Carbon Steel	0.6 – 1.4%
Low Alloy Steel	Approx. 0.15%

Table 1. Carbon Content in Steel

Higher carbon content means stronger steel.

Plain carbon steels contain only iron and carbon as main alloying elements, but traces of Mn, Si, Al, S & P may also be present.

Manganese up to ~ 0.8% - Low strength and moderate toughness

High Manganese up to ~ 1.6% improves the toughness.

1.3.2 Cast Iron

Cast iron has higher carbon and silicon content and is not as ductile.

In terms of welding metals, low carbon steel is easier to weld than cast iron.

Cast iron is generally welded with oxyacetylene welding.

1.3.3 Alloy Steels

Low Alloy Steels <7% alloying elements

High Alloy Steels >7% alloying elements

Alloy Steels are considered the type of steels that predominantly contain extra alloying elements other than iron and carbon.

1.3.4 Stainless steel

Stainless steels generally contain between 10 - 20% chromium as the main alloying element and are valued for high corrosion resistance. With over 11% chromium, steel is about 200 times more resistant to corrosion than mild steel. These steels can be divided into 5 groups based on their crystalline structure:

- a. Ferritic and martensitic alloys
- b. Austenitic stainless steels
- c. Duplex stainless steel
- d. Precipitation-hardened materials

Stainless is welded using arc welding (TIG, MIG or Stick).

1.3.5 Tool Steel

Tool steels contain tungsten, molybdenum, cobalt, and vanadium in varying quantities to increase heat resistance and durability, making them ideal for cutting and drilling equipment.

Steel products can also be divided by their shapes and related applications:

Long/Tubular Products include bars and rods, rails, wires, angles, pipes, and shapes and sections. These products are commonly used in the automotive and construction sectors.

Flat Products include plates, sheets, coils, and strips. These materials are mainly used in automotive parts, appliances, packaging, shipbuilding, and construction.

Other Products include valves, fittings, and flanges and are mainly used as piping materials.

1.4 Alloying Elements in Steel

Steel is a combination of iron, carbon, and some others alloy and non-alloyed.

Steel is alloyed with various elements to improve physical properties and to produce special properties such as resistance to corrosion or heat. Different alloy elements have different effects to steel Mechanical and Physical properties.

Most elements can have many effects on the properties of steels.

And other factors which affect material properties are:

- a. The temperature reached before and during welding
- b. Heat input
- c. The cooling rate after welding and or PWHT

Specific effects of the addition of such elements are as below:

1.4.1 Iron (Fe)

Main steel constituent. On its own, is relatively soft, ductile, with low strength.

1.4.2 Carbon (C)

Major alloying element in steels, a strengthening element with major influence on HAZ hardness. Decreases weldability. Typically, $< \sim 0.25\%$

1.4.3 Manganese (Mn)

Manganese improves strength and toughness. Typically, $< 0.8\%$ is residual from steel de-oxidation and up to $\sim 1.6\%$ (in C-Mn steels) improves toughness.

Its manner has below main effects:

- a. It is a mild deoxidant acting as a cleanser taking the Sulphur and oxygen out of the melt into the slag.
- b. It increases the harden potential and tensile strength but decreases ductility.
- c. It combines with Sulphur to form globular manganese sulphides, essential in free cutting steels for good machinability.

1.4.4 Silicon (Si)

- a. Residual element from steel de-oxidation. typically to $\sim 0.35\%$.
- b. Silicon is one of the principal de-oxidizers for steel. Silicon helps to discarding bubbles of oxygen from the molten steel.
- c. Silicon dissolves in iron and tends to strengthen it, enhanced cleaning, and de-oxidation for welding on contaminated surfaces. So, these filler metals are used for welding on clean surfaces, the resulting weld metal strength will be markedly increased. Silicon increases strength and hardness but to a lesser extent than manganese.
- d. The resulting decrease in ductility could resent cracking problems.

1.4.5 Phosphorus (P)

Residual element from steel-making minerals. Difficult to reduce below $< \sim 0.015\%$ brittleness.

Although it increases the tensile strength of steel and improves machinability it is generally regarded as an undesirable impurity because of its embrittling effect.

Effect of phosphorus element will have various effects on steel depending on concentration.

The maximum amount of phosphorus in higher grade steel is between 0.03 to 0.05%. Up to 0.10% of phosphorus in low-alloy high-strength steels will increase the strength as well as improve the steel's resistance against corrosion. The possibility of brittlement increases when the content in hardened steel is too high. Even though the strength and hardness are improved, the ductility and toughness decreases.

The machinability is improved in free-cutting steel, but weld brittle and/or weld cracks can occur during welding if the phosphorus content is more than 0.04%. Phosphorus also affects the thickness of the zinc layer when galvanizing steel.

1.4.6 Sulphur (S)

Residual element from steel-making minerals.

Typically, < ~ 0.015% in modern steels < ~ 0.003% in very clean steels

Sulfur is normally regarded as an impurity and has an adverse effect on impact properties when a steel is high in Sulphur and low in manganese.

Sulphur improves machinability but lowers transverse ductility and notched impact toughness and has little effects on the longitudinal mechanical properties.

Free cutting steels have Sulphur added to improve machinability, usually up to a maximum of 0.35%.

Even though the effect of Sulphur on steel is negative at certain stages, any Sulphur content less than 0.05% has a positive effect on steel grades.

1.4.7 Aluminum (Al)

De-oxidant and grain size control. typically, ~ 0.02 to ~ 0.05%

Aluminum is one of the most important deoxidizers in very small amounts in the material and helps form a more fine-grained crystalline microstructure and increase the steel grade's toughness.

1.4.8 Chromium (Cr)

For creep resistance & oxidation (scaling) resistance for elevated temperature service. Widely used in stainless steels for corrosion resistance, increases hardness and strength but reduces ductility. Typically, ~ 1 to 9% in low alloy steels

Cr presents in certain structural steels in small amounts. It is primarily used to increase hardenability of steel and increase the corrosion resistance as well as the yield strength of the steel material.

When the percent of chromium in the steel exceeds 1.1% a surface layer is formed that helps protect the steel against oxidation.

1.4.9 Nickel (Ni)

Used in stainless steels, high resistance to corrosion from acids, increases strength and toughness

In addition to its favorable effect on the corrosion resistance of steel, Ni is added to steels to increase hardenability. Nickel enhances the low-temperature behavior of the material by improving the fracture toughness.

The weldability of the steel is not decreased by the manner of this element. The nickel drastically increases the notch toughness of the steel.

Nickel is often used in combination with other alloying elements, especially chromium and molybdenum. It is a key component in stainless steels but at the low concentrations found in carbon steels.

1.4.10 Nickel Alloys

Nickel welding metals come in the form of several alloys. These include:

Nickel Alloy 141: Used for welding case and wrought pure nickel (nickel 200 and 201). It is also used to join nickel to steel.

Nickel Alloy 61: Same as above.

Nickel-Copper Alloy 190: For welding to itself or to steel.

Nickel-Copper Alloy 60: Used for welding to itself.

1.4.11 Magnesium

Magnesium alloys are lightweight (2/3 of aluminum), it absorbs vibration and is easy to cast. It has a melting temperature like aluminum and is welded in a similar way.

When you grind magnesium note that the shavings are flammable (do not use water to put out any flames). The metal is welded with a Tig welder.

1.4.12 Molybdenum (Mo)

Affects hardenability. Steels containing molybdenum are less susceptible to temper brittleness than other alloy steels. Increases the high temperature tensile and creep strengths of steel. Typically, ~ 0.5 to 1.0%

Molybdenum has effects similar to manganese and vanadium and is often used in combination with one or the other. This element is a strong carbide former and is usually present in alloy steels in amounts less than 1%. It increases hardenability and elevated temperature strength and also improves corrosion resistance as well as increased creep strength. It is added to stainless steels to increase their resistance to corrosion and is also used in high speed tool steels.

1.4.13 Niobium (Nb)

Niobium is a key grain refining element, as well a strength-enhancing element in steel production. Niobium is a strong carbide former and forms very hard, very small, simple carbides. Improves ductility, hardness, wear, and corrosion resistance. Also, refines grain structure. Formerly known as Columbium.

1.4.14 Vanadium (V)

A grain refiner, typically ~ 0.05%

The effects of Vanadium chemical element are similar to those of Mn, Mo, and Cb. When used with other alloying elements it restricts grain growth, refines grain size, increases

hardenability, fracture toughness, and resistance to shock loading. Softening at high temperatures, fatigue stress and wear resistance are improved. At greater than 0.05%, there may be a tendency for the steel to become embrittled during thermal stress relief treatments.

Vanadium is used in nitriding, heat resisting, tool and spring steels together with other alloying elements.

1.4.15 Titanium (Ti)

Titanium is used to control grain size growth, which improves toughness. Also transforms sulfide inclusions from elongated to globular, improving strength and corrosion resistance as well as toughness and ductility.

Ti is a very strong, very lightweight metal that can be used alone or alloyed with steels. It is added to steel to give them high strength at high temperatures. Modern jet engines used titanium steels.

It prevents localized depletion of chromium in stainless steels during long heating

Prevents formation of austenite in high chromium steels

Reduces martensitic hardness and hardenability in medium chromium steels.

1.4.16 Copper (Cu)

Present as a residual, (typically < ~ 0.30%) added to 'weathering steels' (~ 0.6%) to give better corrosion resistance.

It also has a small impact on hardenability. It is typically found in amounts not less than 0.20 percent and is the primary anti-corrosion component in steel grades like A242 and A441.

Copper is popular due to its electrical conductivity, heat conductivity, corrosion resistance, appearance, and wear resistance. Copper is also added to produce precipitation hardening properties and increase corrosion resistance.

1.5 Hot Rolled Steel V/s Cold Rolled Steel

1.5.1 Hot Rolled Steel

- a. Is relatively soft as compared to cold rolled products.
- b. Is widely used for general structural fabrication.
- c. Has an oxidized “mill scale” coating which is a dark flat gray color.
- d. Has rounded edges.
- e. Cost less than cold rolled steel.

1.5.2 Cold Rolled Steel

- a. Is somewhat harder than hot rolled steel due to cold compression while forming.
- b. Has a shiner surface and square edges.
- c. Has better dimensional tolerances.
- d. Is used in manufacturing of parts, tools, jigs, fixtures, and tooling.
- e. Cost more than hot rolled steel.

Constituent	Influencing Characteristics
Carbon (C)	Strength
Manganese (Mn)	Toughness
Silicon (Si)	< 0.3% Deoxidizer
Aluminum Al	Grain refiner, <0.008% Deoxidizer + Toughness
Chromium (Cr)	Corrosion resistance and resistance to elevate temp. (secondary only to Mo in creep resistance)
Molybdenum (Mo)	1% is for Creep resistance
Vanadium (V)	Strength
Nickel (Ni)	Low temperature applications and toughness
Copper (Cu)	Used for weathering steels (Corten)
Sulphur (S)	Residual element (can cause hot shortness)

Phosphorous (P)	Residual element (can cause for brittleness) (cold shortness)
Titanium (Ti)	Grain refiner. Used as a micro alloying element. Improves strength and toughness.
Niobium (Nb)	Grain refiner. Used as a micro alloying element. Improves strength and toughness.

Table 2.Summary Table

2 CHAPTER - 2: WELD JOINTS

A welding joint is a point or edge where two or more workpieces are joined.

Weld joints are one of the weakest links in any system due to intrinsic constraints. For high-quality welding, the direction of forces that will be applied to the components after welding must be addressed. These forces affect the quality of the weld and the strength of the joint.

Tensile, compression, bending, torsion, and shear forces create stresses in welded joints, as shown in the figure below.

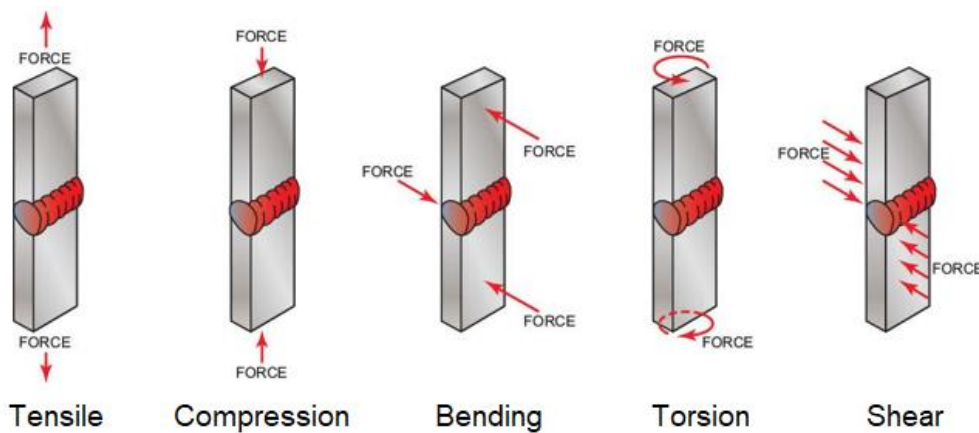

Figure 2. Stresses in welded joints created by Tensile, Compression, Bending, Torsion, Shear Forces

Joint connections in a structure should be designed to fulfil the intended level of safety, serviceability and durability, and the ability to withstand at least the stresses provided for them in the global analysis of the structure. The ability of a welded joint to prevent these forces from causing structural failure depends upon both the joint design. Some joints can withstand some types of forces better than others.

The production of sound welds is governed by type of joint, its preparation, root opening, etc. The choice of electrode, welding position, welding current and voltage, heat input, arc length, rate of travel, penetration, deposition rate also affects the quality of weld.

2.1 Basic Joints

The American Welding Society (AWS) defines five types of joints based on the arrangement of the workpieces: Butt, Lap, Corner, Tee, and Edge.

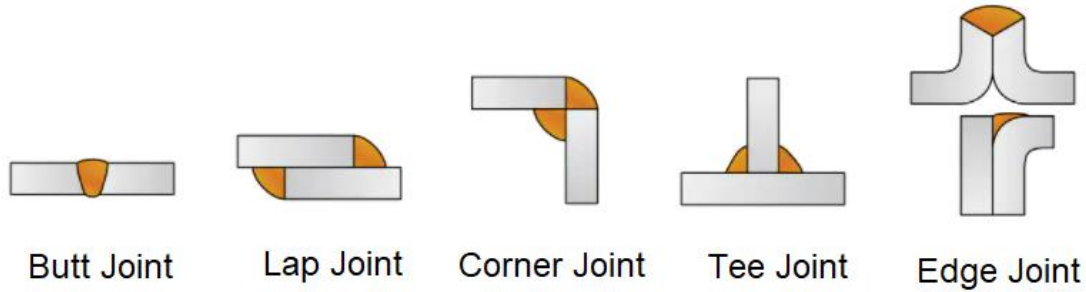

Figure 3. Types of Joints

The types of welded joints depend on:

- a. Size and shape of members connected at joint
- b. Type of loading
- c. Area available for welding
- d. Relative cost of various types of weld.

2.1.1 Butt Joint

A butt joint is a joint where two pieces of metal lie in one plane and the side of each metal is joined by welding.



Figure 4. Butt Joint

A butt weld is the most common type of joint used in the manufacture of structures and piping systems. Butt welds are made in different ways, each serving a different purpose. Different factors are the shape of the groove, the layering, and the width of the gap.

Note that the butt welds and groove welds refer to the same weld type, where groove weld is the American National Standards Institute (ANSI) term, and butt weld is the International Organization for Standardization (ISO) term.

2.1.2 Tee Joints

Tee welding joints are formed when two workpieces lie at a right angle to each other. This results in the edges coming together in the center of a plate or component in a 'T' shape.

Tee joints are a type of fillet weld, and they can also be formed when a tube or pipe is welded onto a base plate. A double T-joint occurs when one piece is attached from both sides at right angles to another to be welded.



Figure 5. Tee Joint

With this type of weld, it's important to always ensure there is effective penetration into the roof of the weld. Tee joints are not usually prepared with groove, unless the base metal is thick and welding on both sides cannot withstand the load the joint must support.

2.1.3 Corner Joints

Corner joints have similarities to tee welding joints. However, the difference is the location of where the metal is positioned. In the tee joint, it's placed in the middle, whereas in corner joints the ends of both workpieces abut at a corner. It does not matter whether they are at a 90-degree angle or any other angle (< 180 degrees) to each other.



Figure 6. Corner Joints

The styles used for creating corner joints include V-groove, J-groove, U-groove, spot, edge, fillet, corner-flange, bevel-groove, flare-V-groove and square-groove or butt.

2.1.4 Lap Joints

Lap joints are formed when two pieces of metal lie parallel on top of each other and overlap. In this case one workpiece protrudes over another.

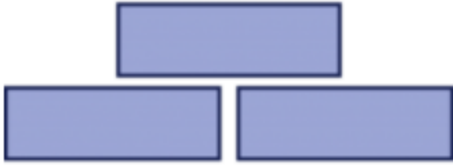

Figure 7. Lap Joints

Lap joints are rarely used on thicker materials and are commonly used to joint two pieces with differing thicknesses together. Welds can be made on one or both sides.

2.1.5 Edge Joints

In an edge joint, the metal surfaces are placed together so that the edges are even. One or both plates may be formed by bending them at an angle.

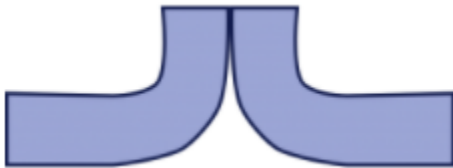

Figure 8. Edge Joints

2.2 Joint Preparations

Joint preparation is a technical term used to describe how you prepare metal for welding. It involves preparation of groove between two members to be welded.

When parts and assemblies demand a certain level of strength, you must cut the edges of the metal and fill it with weld material and creates a complete bridge between the two components. The depth of penetration in a weld joint affects the strength, quality, and efficiency of the welding process.

2.3 Faying Surface and Weld Seams

The area of the metal's surface that is melted during the welding process is called the faying surface. The faying surface can be shaped before welding to increase the weld's strength; this is called edge preparation.

A seam weld is made to join the faying surfaces of two pieces of similar metals in a way that there is not gap or crevice left between them. The seam may be a butt joint or an

overlap joint and is usually an automated process and forms the weld progressively, starting at one end.

The figure below shows dimensions and properties that can be named for a weld seam. Depending on conditions and materials, these properties must be correctly selected to ensure the strength and stability of the weld. The following sections deal with these dimensions and shapes.

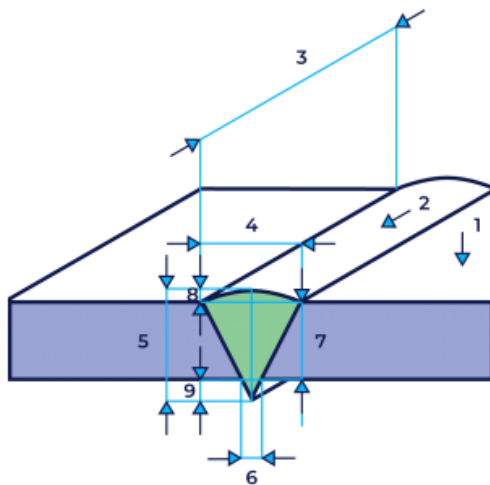

1. Base material
2. Weld metal
3. Seam length
4. Seam width
5. Total seam thickness
6. Root width
7. Actual seam thickness
8. Weld Overlap
9. Root elevation

Figure 9. Dimensions and Properties of Weld Seams

2.4 Principles of Joint preparation

Joint preparation is only possible for certain weld types. For example, root opening preparation is available for square groove or butt, V groove or butt, bevel groove or butt, U groove or butt, J groove or butt, flare V groove or butt, and flare bevel groove or butt welds. Angle cut preparation is available for V groove or butt and bevel groove or butt welds.

Principles for joint preparation for welding include the following:

2.4.1 Codes and standards

Some codes and standards require specific joint preparations.

The type, depth, angle, and location of the groove are usually determined by a code or standard that has been qualified for the specific job.

Organizations such as the American Welding Society, the American Society of Mechanical Engineers (ASME), and the American Bureau of Ships (ABS) are among the agencies that issue such codes and specifications.

The most common code or standards are the AWS D1.1 and the ASME Boiler and Pressure Vessel (BPV), Section IX.

2.4.2 Metals

Because some metals have specific problems with thermal expansion, crack sensitivity, or distortion, the joint design selected must help control these problems.

For example, magnesium is very susceptible to post weld stresses, and the U-groove works best for thick sections.

2.4.3 Joint Dimensions

For groove weld, the root opening or gap is provided for the electrode to access the base of the joint. The size of root gap and root face depends on the following:

- a. Type of welding process
- b. Welding position
- c. Volume of deposited material
- d. Cost of preparing edges
- e. Access for arc and electrode
- f. Shrinkage and distortion

In some cases, the exact size, shape, and angle can be specified for a groove. If exact dimensions are not available, you may make the groove any size you feel necessary; but, remember, the wider the groove, the more welding it will require to complete.

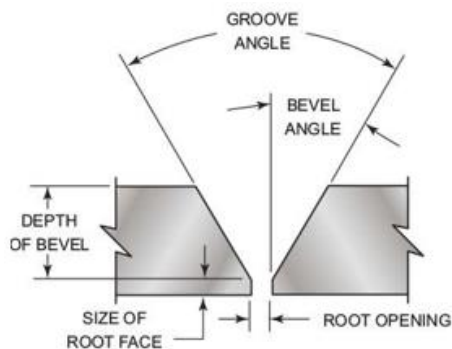

Figure 10. V-Groove

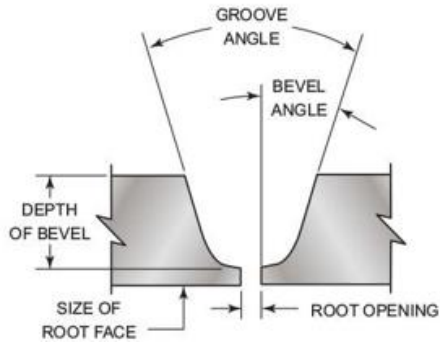

Figure 11. U-Groove

As the metal becomes thicker, you must change the joint design to ensure a sound weld. On thin sections, it is often possible to make full penetration welds using a square butt joint. Square butt joints take less preparation time and less welding time.

When welding on thick plate or pipe, it is often impossible for the welder to get 100% penetration without some type of groove being used. The edge may be shaped with either a bevel, V-groove, J-groove, or U-groove.

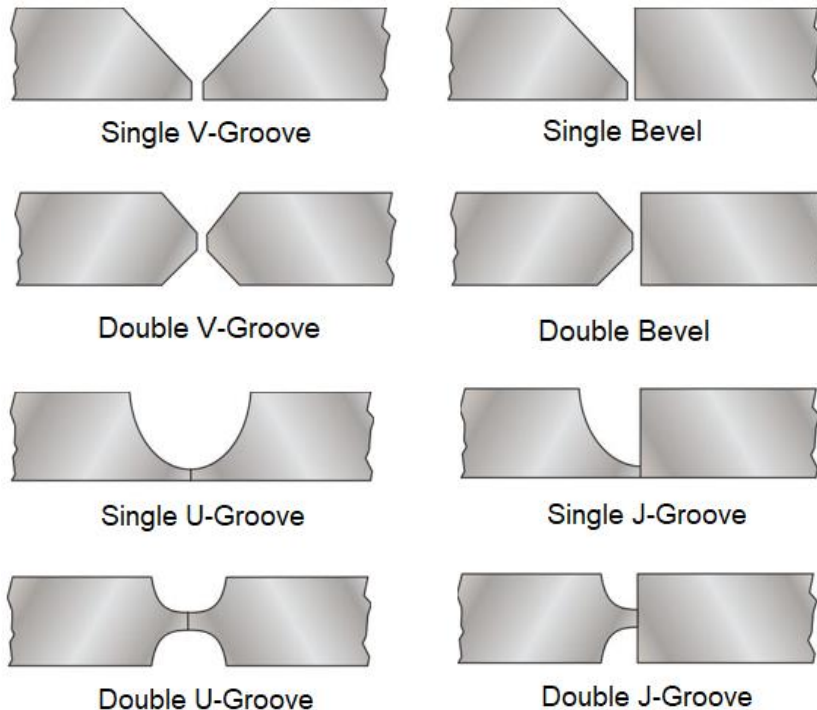

Figure 12. Types of Grooves

Groove welds will transmit full load of the members they join, so they should have the same strength as the members they join.

- a. The groove is made of double-bevel or double-V for plates of thickness more than 12mm.
- b. The groove is made of double-U or double-J for plates of thickness more than 40mm.
- c. The groove is made of single-J and single-U for plates of thickness between 12-40mm.
- d. Effective length of groove weld should not be less than 4 times the weld size. Effective length of intermittent weld should not be less than 4 times the weld size, with a minimum of 40mm.

2.4.4 Fillet Welds

Fillet welds require less precision in fitting up two sections. They are adopted in field as well as shop welding. They are assumed to fail in shear and are cheaper than groove welds. Listed below are the key features:

- a. The minimum size of fillet weld should not be less than 3mm and not more than thickness of thinner part joined. The maximum size of fillet weld is obtained by subtracting 1.5mm from thickness of thinner member to be jointed. The maximum size of weld should not be more than $\frac{3}{4}$ of the thickness of section at toe when welds are applied to round toe of steel sections.
- b. As per IS code, the actual length of fillet weld should not be less than four times the size of weld. If this requirement is not met, the size of weld should be one fourth of the effective length.
- c. Effective length of fillet weld is taken equal to overall length minus twice the weld size. The deduction is made to allow for craters to be formed at the ends of welded length.

2.4.5 Corner Joints Preparations

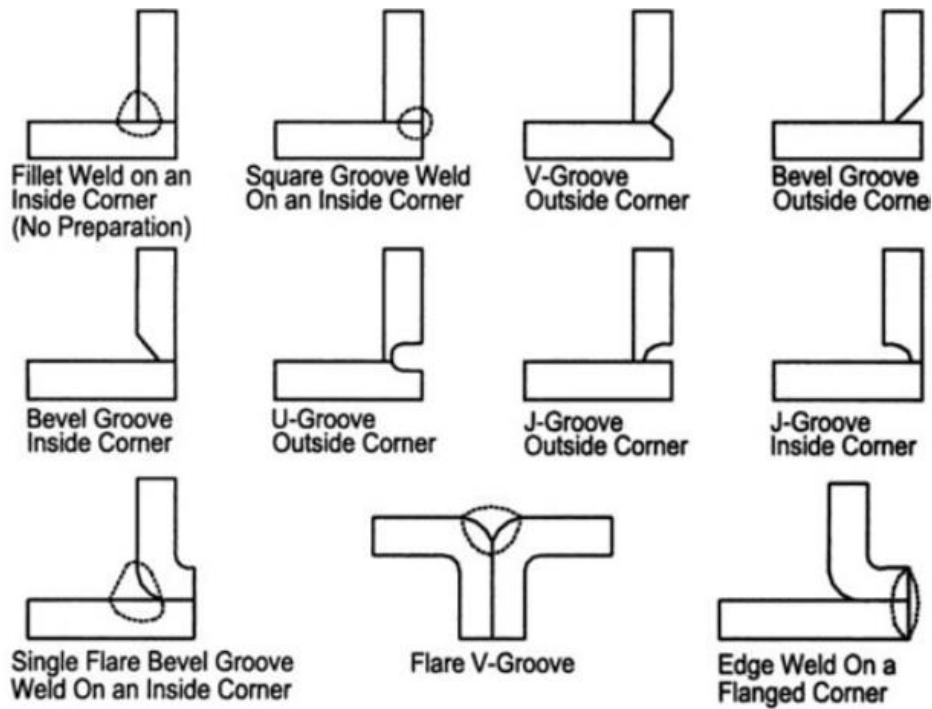

Figure 13. Corner Joints Edge Preparations

2.4.6 Edge Joint Preparations

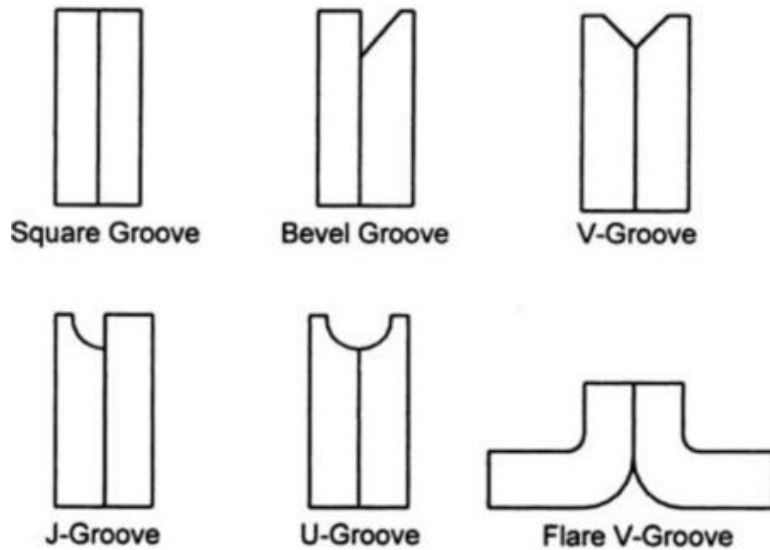

Figure 14. Edge Joints-Edge Preparations

2.4.7 Lap Joint Preparations

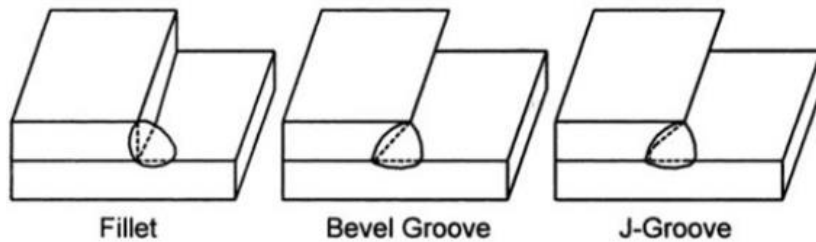

Figure 15. Lap Joints Edge Preparation

2.4.8 Tee Joint Preparations

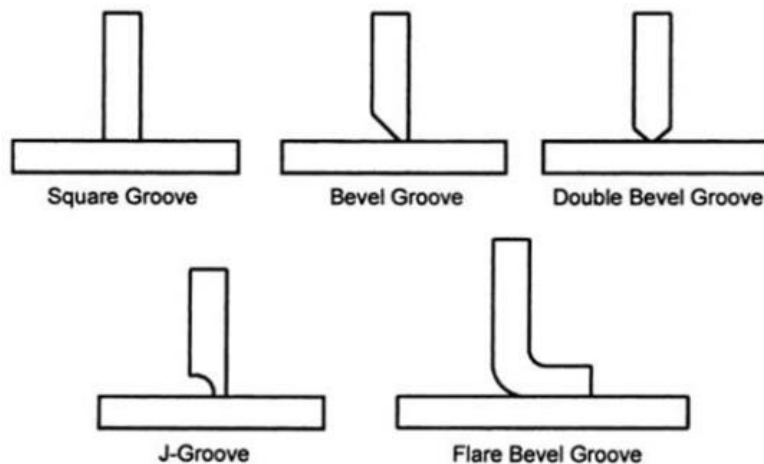

Figure 16. Tee Joint Edge Preparations

2.4.9 Smooth appearance

The weld's surface can be ground smooth with the base metal so that the weld "disappears." This can be done for appearance or so that the weld does not interfere with the sliding or moving of parts along the surface.

2.4.10 Increased strength

A weld should be as strong as or stronger than the base metal being joined. By having 100% joint fusion and an appropriate amount of weld reinforcement, the weld can meet its strength requirement.

2.4.11 Welding Position

The most ideal welding position for most joints is the flat position because it allows for larger molten weld pools to be controlled.

When welds are made in any position other than the flat position, they are referred to as being done out of position.

The American Welding Society (AWS) has divided plate welding into four basic positions for grooves (G) and fillet (F) welds as follows:

In plate welding, we have four different positions namely:

- a. Flat position (1G or 1F)
- b. Horizontal Position (2G or 2F)
- c. Vertical Position (3G or 3F)
- d. Overhead Position (4G or 4F)

2.4.11.1 Groove Weld Positions

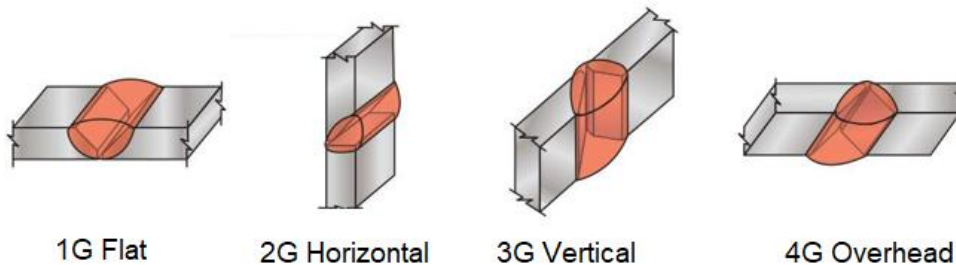

Figure 17. Groove Weld Positions

2.4.11.2 Fillet Weld Positions

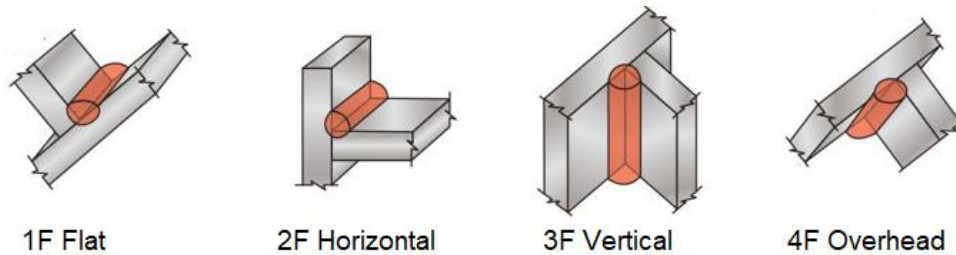

Figure 18. Fillet Weld Positions

Notes:

- a. In flat welding the welders head remains above the test coupon.
- b. In horizontal weld position, movement of electrode shall be in horizontal plane. We have two different welding techniques in horizontal welding, these are:
 - Rightward technique
 - Leftward Technique
- c. In vertical weld position, movement of electrode shall be in vertical plane. We have two different welding methods in vertical welding, these are:
 - Uphill
 - Downhill
- d. Overhead position is one of the most difficult positions because welder has to work against the gravity. In overhead welding, the test coupon (or workpiece) remains above the head of the welder.

2.4.12 Welder Skill

Often the skills or abilities of the welder are a limiting factor in joint design.

Some joints have been designed without adequate room for the welder to see the molten weld pool or room to get the electrode or torch into the joint.

2.4.13 Costs

Several factors can affect the cost of producing a weld.

Joint design is one major way to control welding cost. Reducing the groove angle can help.

Joint design must be a consideration for any project to be competitive and cost effective.

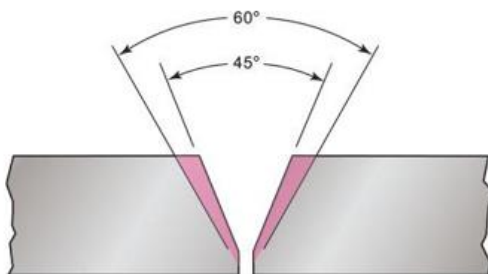

Figure 19. Groove Angle

3 CHAPTER -3 WELDING SYMBOLS

Welding symbols are a useful tool for managing the welding of a specific connection. Every weld symbol is a compact set of instructions written in a code that experienced welders can quickly interpret to determine how they should handle every weld in a custom fabrication.

Welding symbols are used on drawings, project specs, and welding procedure specifications.

The information in the welding symbol can include the following details for the weld: weld type, location, size, length, depth of penetration, height of reinforcement, groove type, groove dimensions, location, process, filler metal, strength, number of welds, weld shape, and surface finishing.

Welding symbols are part of the language of welding. Welders must be able to understand this language to ensure their welds meet the design specs.

Weld symbols are one of the most critical elements for technical documentation and communication with the welder. Reading and understanding weld symbols the right way is essential to do a great welding job in [year].

In this chapter, you will find the most basic weld symbols.

3.1 Weld symbol vs Welding symbol

A weld symbol is not the same as a welding symbol.

The weld symbol specifies the type of weld to be applied to a part and is usually a part of the welding symbol. The welding symbol describes the whole thing and consists of several parts including the reference line, arrow, and weld symbol when required. The weld symbol is placed above the reference line of the welding symbol.

Welding symbol

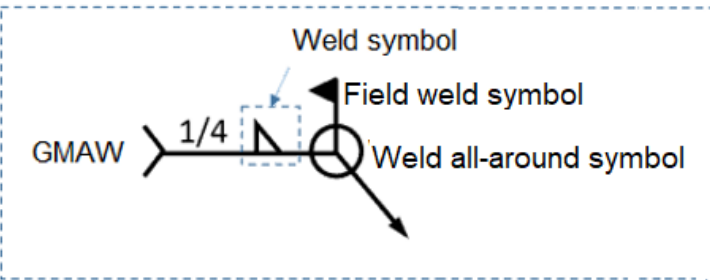

Figure 20. Welding Symbol vs Weld Symbol

3.1.1 Illustration of Welding Symbol

Welding symbols are a set of information conveyed by the design department to the welding engineer and the welding operator. It contains all the necessary information viz. welding position, dimensions and geometry of the weld, details of groove/fillet, welding process, etc.

A basic weld symbol consists of three parts:

- An arrow to indicate where the weld is required.
- The reference line, which is always horizontal. This line typically has a symbol attached to it to indicate the type of weld to be made. In most weld symbols, the reference line will contain the majority of the information needed about the weld, including the type of weld to be made, length of weld, weld size, and required beveling of the weld area can all be communicated on one small line.
- The tail, which is an optional component used to relay special instructions.

These are shown in the diagram given below

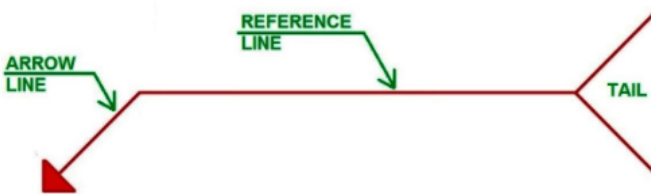

Figure 21. Basic Weld Symbol

In addition to the basic parts of a welding symbol i.e. Arrow line, Reference line, and the tail certain elementary symbols are provided on the reference line. The elementary symbols may be complemented by supplementary symbols, dimensions, and complementary information.

3.2 Welding Symbols

In the following images you can see the basic AWS weld symbols, groove symbols and supplementary weld symbols.

3.2.1 Basic Weld Symbols

Fillet	Plug or Slot	Spot or Projection	Stud	Seam	Backing	Surfacing	Flange	
							Edge	Corner

Figure 22. Basic Weld Symbols

Location	Fillet	Plug or Slot	Spot or Projection	Stud	Seam	Backing	Surfacing	Flange Corner	Flange Edge
Arrow Side									
Other Side				Not used			Not used		
Both Sides		Not used	Not used	Not used	Not used	Not used	Not used	Not used	Not used

Figure 23. Basic Welding Symbols and Their Location Significance

3.2.2 Groove Symbols

Square	V	Bevel	U	J	Flare V	Flare Bevel	Scarf for Brazed Joint

Figure 24. Basic Groove Symbols

Location	Square	V	Bevel	U	J	Flare - V	Flare - Bevel	Scarf for Brazed Joint
Arrow Side								
Other Side								
Both Sides								

Figure 25. Basic Welding Groove Symbols

3.2.3 Supplementary Symbols

Weld All Around	Field Weld	Contour		
		Flush	Convex	Concave

Figure 26. Supplementary Symbols

For further reference you can also check the handout on AWS here.

3.2.4 Why Welding Symbols Matter!

Welding symbols help to convey information clearly. Look at the figure below. You could use the words on the right to describe the welding needed but there may be no room for the drawing itself. Alternatively, you could use the welding symbols on the left. What would you choose?

Explanation	Symbol
Weld both sides 5/16 inches leg length and 12 inches long. The welding process is FCAW.	
Weld the arrow side - 6mm leg length and 100mm long. The center to center of the weld is to be 500mm long.	

Weld the other side - 10mm leg length and 50mm long. The center to center of the weld is to be 200mm long.	
--	--

The most important reason why weld symbols matter is that they aid to assure consistent quality and production tolerances. Welders know exactly where to place their welds, how large to make them, and what kind of weld to apply for the highest overall quality.

Even in modern factories where automated welding machines are used, weld symbols help the welding machine operator program the welding machine to ensure that every weld joint is executed to the exact standards outlined in the design document.

Welding symbols can also give more information than would be possible with words and so save space and time. Once you become accustomed to the symbols you will see that they help you to understand exactly what needs to be done. Symbols can define:

- a. Joint configuration e.g. beveled, butt weld or double bevel
- b. Type of weld e.g. fillet, lap, edge, corner, slot, or plug
- c. Type of welding process e.g. gas metal arc welding
- d. Application e.g. whether to weld on site or in the workshop.

3.3 Interpreting Welding Symbols

3.3.1 Weld Orientation

There are multiple orientations of the arrow possible, however the reference line must be oriented horizontally. In the following image you can see examples of how welding symbols can be arranged, but there are even more combinations possible.

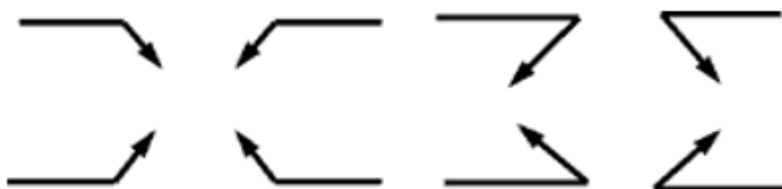

Figure 27. Weld Orientation

3.3.2 Weld Location

Weld information for the “arrow side” can be read below the reference line. Weld information for the “other side” is placed above the reference line.

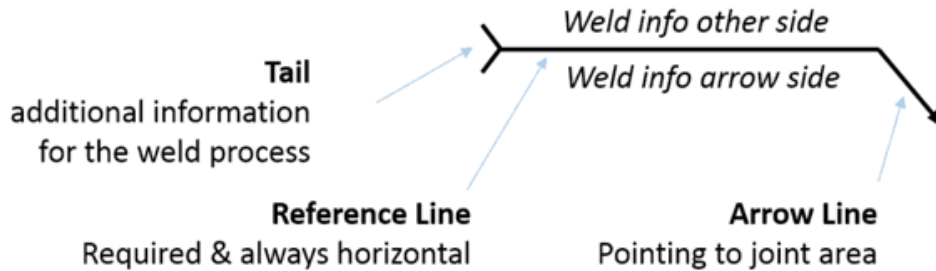

Figure 28. Weld Location

Now, look at the image below. The position of the weld symbol clearly tells the welder where the weld seam should be.

The side at which the arrow is pointing at is called “arrow side”. The opposite side is the “other side”.

Overall, there are three different possible positions for a weld symbol in the welding symbol:

Case #1

If the weld symbol is on the bottom side, the desired weld seam must be placed on the arrow side.

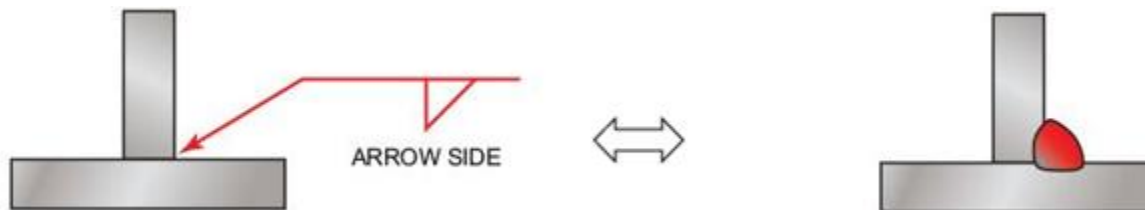

Figure 29. Weld Symbol on Bottom Side

Case #2

If the weld symbol is on the top side, weld seam must be placed on the other side.

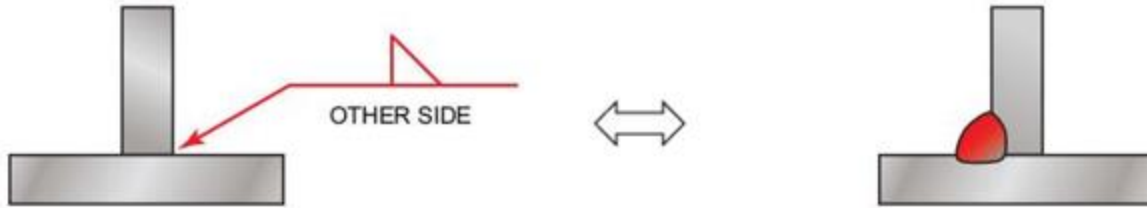

Figure 30. Weld Symbol on Top Side

Case #3

If the weld symbol is on both, on the top and on the bottom side of the reference line, the weld seam must be placed on both sides.

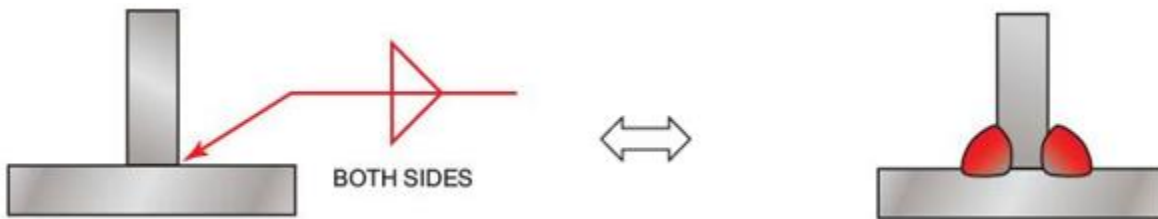

Figure 31. Weld Symbol on Bottom and Top Side

Case #4

If the weld symbol is on both top and on the bottom side for two sides.

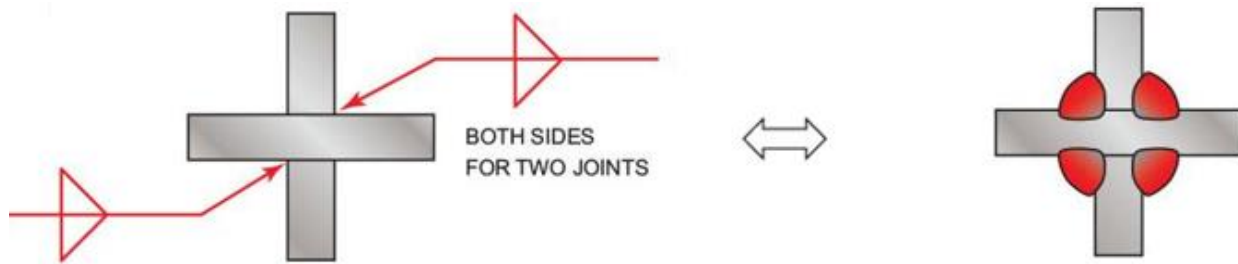

Figure 32. Weld Symbol on Bottom and Top Side for two Sides

3.3.3 Weld All-round

A circle around the intersection between the reference line and arrow line symbolizes to weld completely around something.



Figure 33. Weld All-round Symbol

3.3.3.1 Example

In the following image you can see an example of what it could look like when you use the weld-all-around symbol.

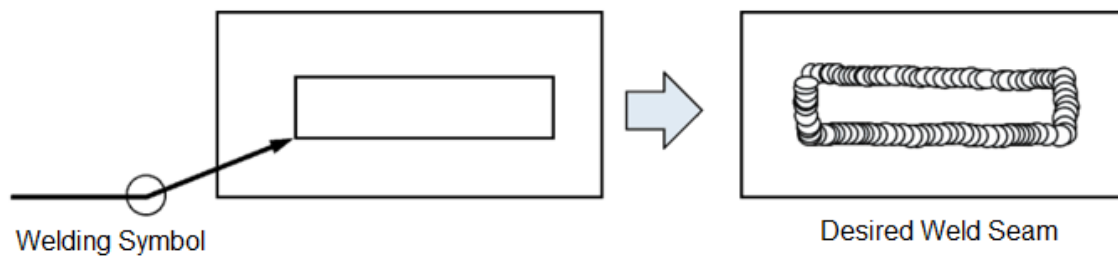

Figure 34. The Use of Weld All-Around Symbol

But in many cases, you don't just want to weld around completely but define a specific length and width of a weld seam.

3.3.4 Field-weld Symbol

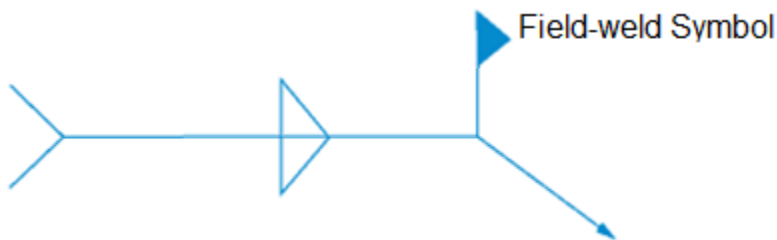
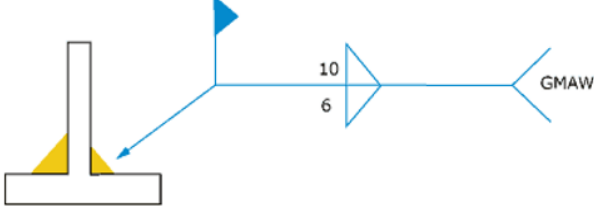
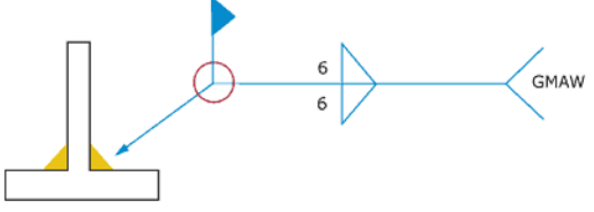

Figure 35. Field-weld Symbol

3.3.4.1 Example

Compare two symbols. Note what is different and what each one means.

<p>10mm fillet weld other side of arrow 6mm fillet weld arrow side</p> <p>Weld on site.</p> <p>Use the Gas Metal Arc Welding Process</p>	
<p>6mm fillet weld on both sides</p> <p>Weld all round</p> <p>Weld on site</p> <p>Use the Gas Metal Arc Welding Process</p>	

3.3.5 Dimensions - The Length and Width of a Weld Seam

The width of the weld is shown on the same side of the reference line as the weld symbol and are shown to the left of the symbol.

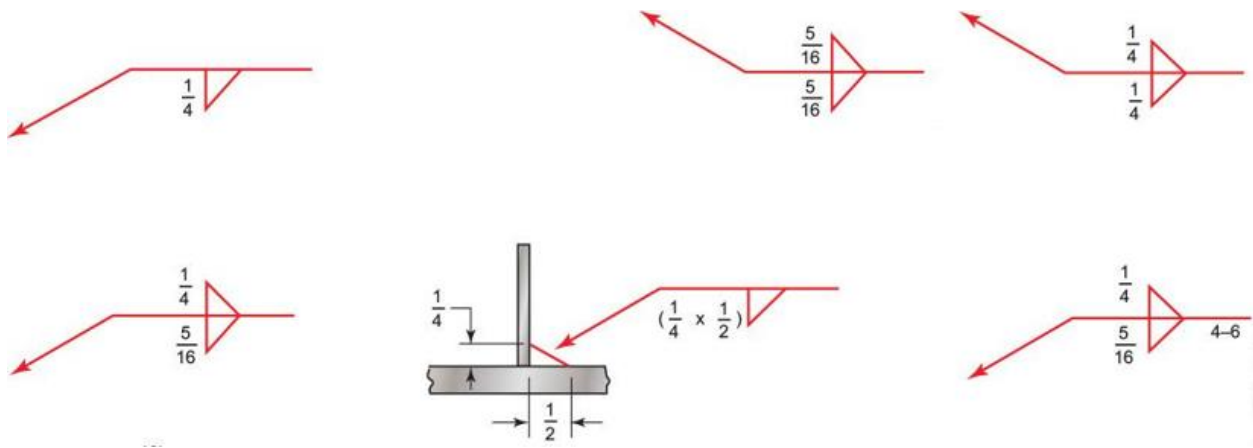

Figure 36. Weld Seam

The length of the weld seam is shown on the right side of the weld symbol. If you would like to specify both the length and the width of a weld seam, you can do it the following way:

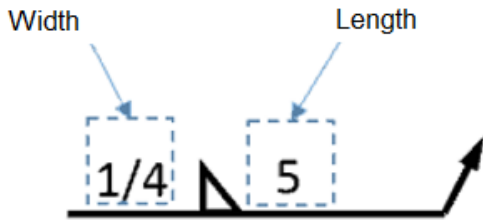

Figure 37.Length and Width Symbol for Weld Seam

This symbol requires a 1/4-inch fillet weld with a length of 5 inch.

3.3.5.1 Example

The following example shows a 1/4-inch fillet weld with a length of 3 placed on the arrow side.



Figure 38.1/4-inch fillet weld with a length of 3 placed on the arrow side

3.3.6 Intermittent Welds

Intermittent welds or also called skip welds are weld seams with unwelded spaces in between. In intermittent fillet welds, the length and pitch increments are placed to the right of the weld symbol.

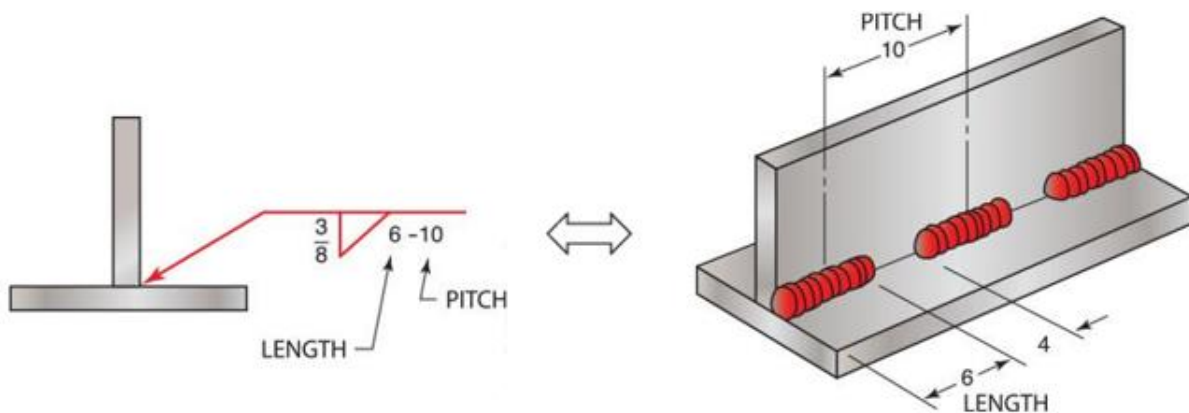

Figure 39.Intermittent Fillet Welds

3.3.6.1 Example

In the following image, you see an example of an intermittent weld with 1/2-inch weld thickness, weld length of 8 inch and a pitch of 12 inch.

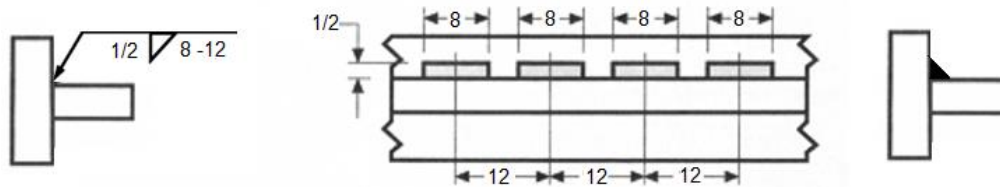

Figure 40. Intermittent weld with 1/2-inch weld thickness, weld length of 8 inch and a pitch of 12 inch

In the following image, you see an example of an intermittent weld (both sides) with 1/8-inch weld thickness, weld length of 5 inch and a pitch of 10 inch.

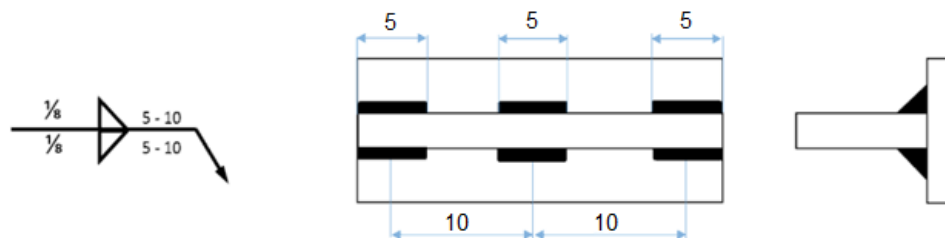

Figure 41. Intermittent weld (both sides) with 1/8-inch weld thickness, weld length of 5 inch and a pitch of 10 inch

3.3.7 Staggered Welds

If you would like to have a staggered weld, you misalign the weld symbols inside the welding symbol.

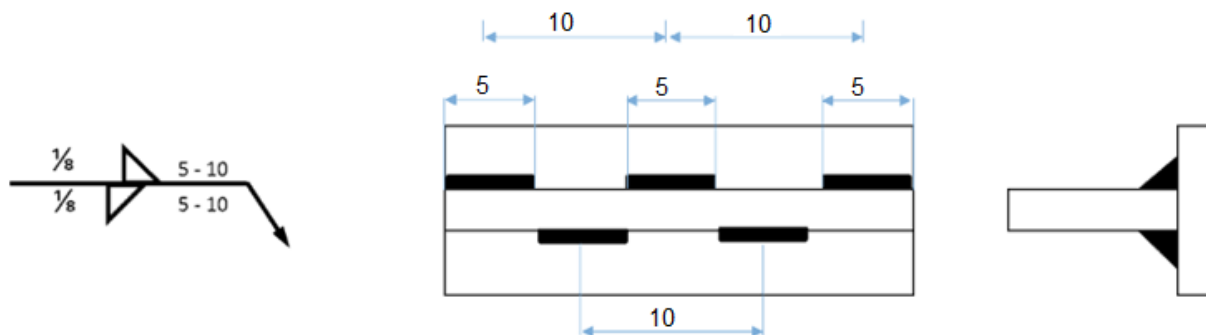

Figure 42. Staggered Welds

3.3.8 Multiple Arrows in a Single Symbol

Welding symbols are frequently constrained by the amount of space available on a drawing. To minimize the number of welding symbols required, it is permitted to use more

than one arrow in a single welding symbol to reduce the number of welding symbols required. A multiple arrow welding symbol can be highly useful, especially around closed corners, because a welding symbol only defines welding of the joint to which an arrow is pointing, and a change of direction or change in geometry constitutes the end of a joint.

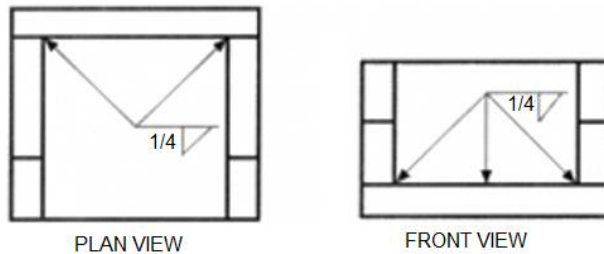

Figure 43. Multiple Arrows in Single Symbol

3.3.9 Multiple Reference Line

A multiple-reference-line welding symbol can be used to specify the sequence of operations. Two or more reference lines may be connected to the same arrow, with the reference line closest to the arrow indicating the first operation and the operations specified by the sequence of reference lines reading upward or downward from the arrow indicating the second and third operations, respectively. It should be noted that a multiple-reference-line symbol can be used to describe processes other than welding, such as nondestructive tests.

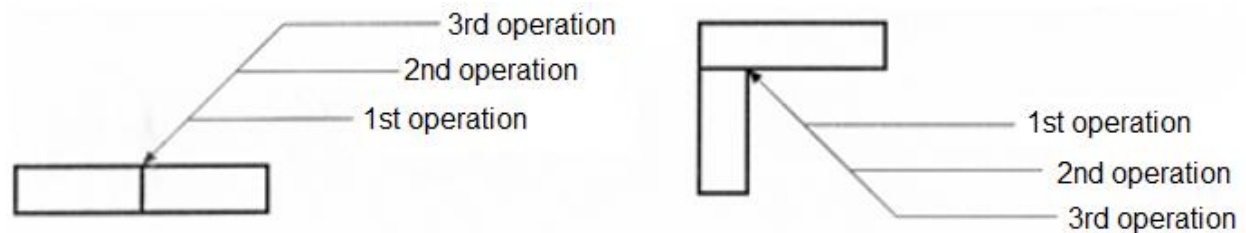

Figure 44. multiple-reference-line welding symbol

3.3.10 Tail Symbols

The notation placed in the tail of the symbol may indicate the welding process to be used, the type of filler metal needed, whether peening or root chipping is required, and other information pertaining to the weld. If notations are not used, the tail of the symbol is omitted.

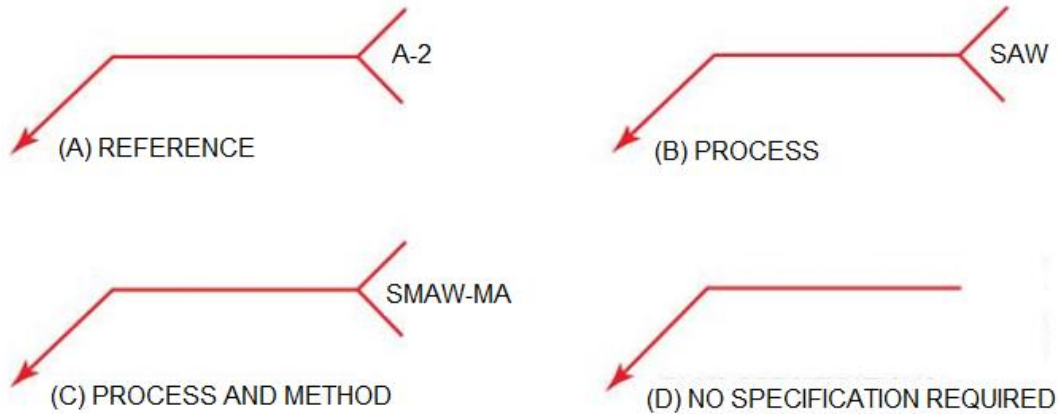

Figure 45. Tails Symbols

(A) Reference: Means refer to reference note A-2

(B) Process: Means welding process is Submerged Arc Welding

(C) Process & Method: Means welding process is Shielded Metal Arc Welding and method is manual

(D) No Specification Required: Means follow general good engineering practices.

3.4 Difference between AWS and ISO Symbols

In the ISO system, a weld on the arrow side is indicated by placing the weld symbol above the solid reference line and a weld on the other side is shown below a dashed line, as shown in the figure given below.

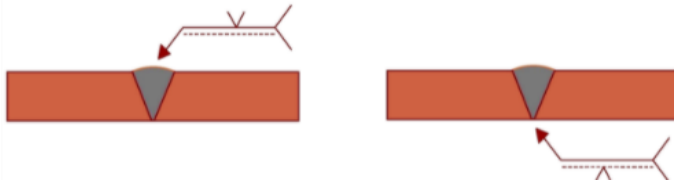

Figure 46. ISO Symbol

Whereas in the AWS system the weld symbol for a weld is placed below the reference line and for a weld on the other side is shown above the line as shown in the figure given below; (Note: Dashed line is not used in AWS system).

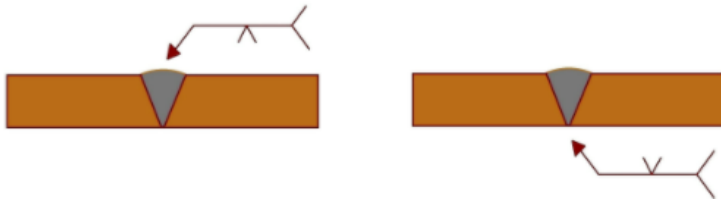

Figure 47.AWS Symbol

In the ISO system symbols on the solid line always refer to the arrow side of the joint and symbols on the dashed line indicate a weld on the other side. The dashed line can be drawn either above or below the solid line but as per standard practice, the dashed line is placed below the solid reference line.

To bring more clarity about the arrow side and the other side in a fillet joint, please see the diagram given below.

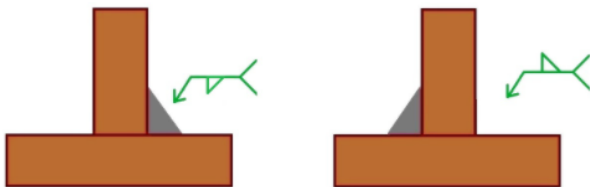

Figure 48.AWS

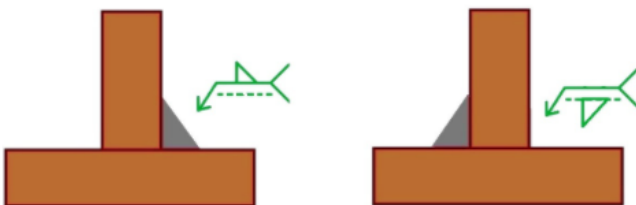

Figure 49.ISO

Note: If the weld is made on both sides, as in a double fillet weld (or double groove), the dashed line can be omitted since the weld symbol is placed on both sides of the reference line or lines. Please see the diagram given below.

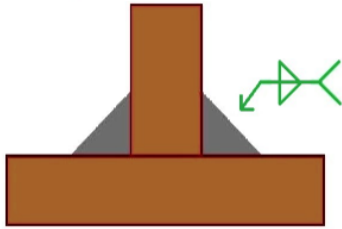

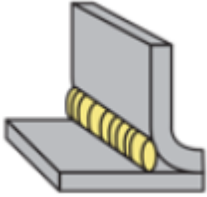
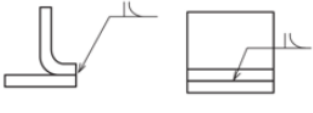
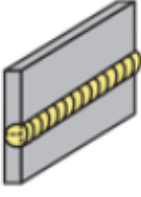

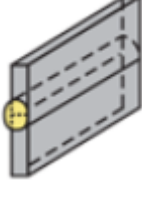

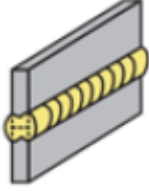

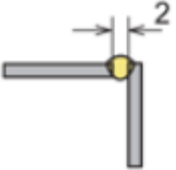
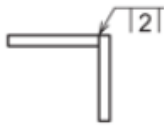
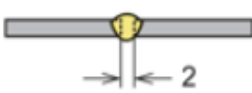

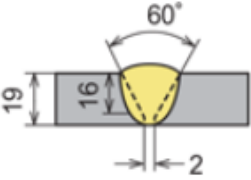
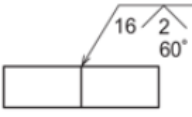
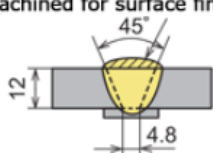
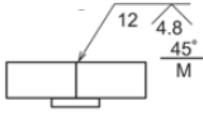
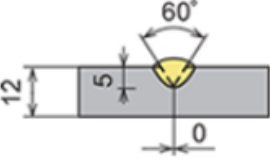

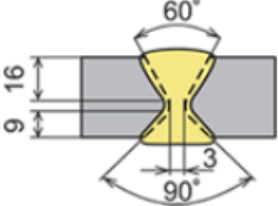
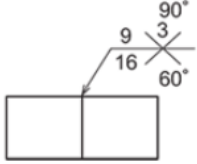
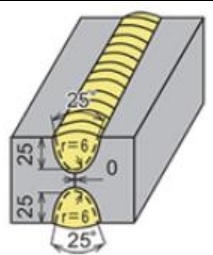
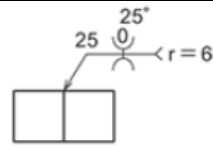
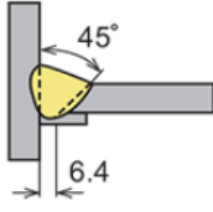
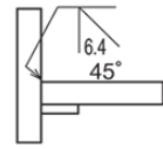
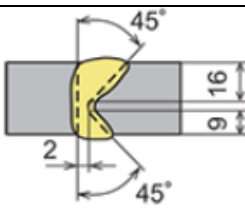
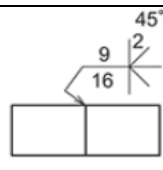
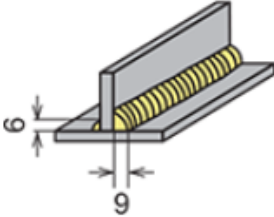
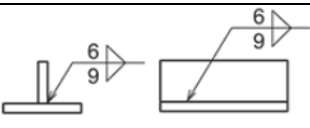

Figure 50. Welding on Both Sides (AWS and ISO)

3.5 Practice Examples

Weld profile	Actual weld joint	Welding symbol
The arrow side or the near side		
The opposite side or the other side of the arrow		
The arrow side or the near side		
The opposite side or the other side of the arrow		

Weld profile	Actual weld joint	Welding symbol
Both sides		
For a root gap of 2mm		
For a root gap of 2mm		
Welds with 16-mm groove depth, 60° groove angle, 2-mm root gap, and 19-mm plate thickness		
Welds with steel backing: 12-mm plate thickness, 45° groove angle, 4.8-mm root gap, machined for surface finishing	<p>Machined for surface finishing</p> 	
Partial penetration weld: 12-mm plate thickness, 5-mm groove depth, 60° groove angle, 0-mm root gap		

Weld profile	Actual weld joint	Welding symbol
<p>Groove depth: 16mm on the arrow side, and 9mm on the opposite side; Groove angle: 60° on the arrow side, 90° on the opposite side; Root gap: 3mm</p>		
<p>On both sides: 25-mm groove depth, 25° groove angle, 6-mm root radius, 0-mm root gap</p>		
<p>T joint with steel backing: 45° groove angle, 6.4-mm root gap</p>		
<p>Groove depth: 16mm on the arrow side, 9mm on the opposite side; Groove angle: 45° on the arrow side, 45° on the opposite side; Root gap: 2mm</p>		
<p>Fillet welds with different leg length on both sides</p>		

Weld profile	Actual weld joint	Welding symbol
Fillet welds with 6-mm leg length on both sides		
Parallel welds: 50-mm weld length, 3 welds, 150-mm pitch		

Summary

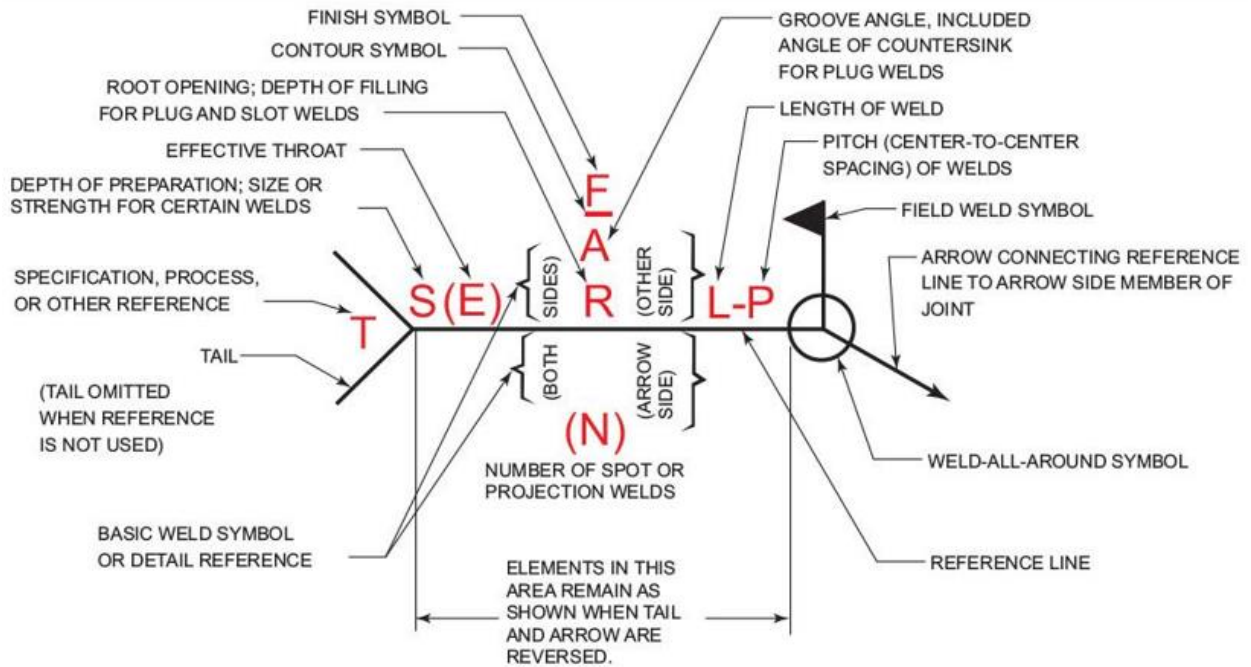

Figure 51. Consolidated Welding Symbol

4 CHAPTER - 4: TECHNOLOGY OF WELDING PROCESSES

There are basically five common arc welding processes used.

- a. Shielded Metal Arc Welding (Stick)
- b. Submerged Arc Welding (Sub-Arc)
- c. Flux-Cored Arc Welding (Flux-Cored)
- d. Gas Metal Arc Welding (MIG)
- e. Gas Tungsten Arc Welding (TIG)

Each process has benefits and drawbacks that can help you choose the best welding method for your project. An outline of each process is provided below.

4.1 Shielded Metal Arc Welding (SMAW)

Shielded metal arc welding or stick welding is the most common manual welding method. It's the most adaptable and uses the least amount of gear. The small light electrode and holder can be used in tight locations or hundreds of feet away from the welding power source.

The equipment cost is relatively inexpensive (starting around \$300), but the overall cost of using this process can be high. This is due to the low deposition rate (pounds of deposited weld metal per hour), which is usually between two and five pounds per hour. The arc is continually interrupted because it is just 14 inches long and the electrode needs to be constantly replaced. As a result, there is downtime, stub loss and inefficiency which drives up the labor cost.

Stick welding is of great quality, but it requires skilled welders. Because the heat input is low, the weld metal has a fine microstructure. This results in excellent mechanical qualities; nevertheless, slag inclusions can form if the slag that protects the molten weld metal from the atmosphere is not cleaned thoroughly between passes and at the end and beginning of each weld. Large welds have a lot of stops and starts, which is where flaws are frequently identified.



Figure 52. Shielded Metal Arc Welding (Stick)

4.2 Submerged Arc Welding (SAW)

Submerged Arc Welding (SAW) is the cheapest welding procedure in general, although the equipment is expensive. Because sub-arc welding is usually a machine or automatic welding process that can only function in the flat and horizontal positions, it can be quite expensive on carriages, turning rolls, manipulators, welding heads, and power supplies.

Submerged arc welding has, with its high amperage (over 1,000 amps), can produce strong penetration and high deposition rates in carbon steel plates. With as many as five wires going into the weld puddle at the same time, sub-arc can deposit over 100 pounds per hour. Significant cost savings can be achieved along with high production rates.

However, it has a few drawbacks. Sub-arc can only be done in the flat and horizontal positions because of the granular flux and fluid weld puddle. The high heat inputs associated with high amperage tend to make large grains in the finished weld metal. The large grains and some micro-inclusions from the slag system tend to create lower mechanical properties than some of the lower heat input methods, although they can still be quite good.



Figure 53. Submerged Arc Welding (Sub-Arc)

4.3 Flux-Cored Arc Welding (FCAW)

Flux-Cored Arc Welding (FCAW) is the most versatile arc welding technique. It's divided into two types: self-shielded and gas shielded.

- a. Self-shielded is typically used outdoors and in situations where high quality mechanical properties aren't necessary.
- b. Gas-shielded is generally used in indoor manufacturing shops where higher-quality mechanical properties are required.

Gas-shielded is the more frequent of the two approaches. It relies on an external supply of shielding gas. CO₂ or a mixture of 75 percent argon and 25 percent CO₂ is commonly used to shield the arc. Weld metal produced by gas-shielded flux-cored arc welding is cleaner and has superior mechanical properties than self-shielded welding.

Large-diameter wires (3/32-inch) provide excellent penetration and can deposit up to 21 pounds per hour. They can only be used in horizontal and flat positions. Small-diameter wires (.035, .045, and 1/16-inch) are excellent for welding out-of-position. They produce the highest deposition rates and quality of any of the all-position processes. They can weld vertically and overhead at a rate of 10 pounds per hour.



Figure 54. Flux-Cored Arc Welding (Flux-Cored)

4.4 Gas Metal Arc Welding (GMAW)

GMAW (Gas Metal Arc Welding) is a fusion welding technology that creates an electric arc between a consumable electrode and the base metals. This arc provides the heat required to melt the base plate's faying surfaces and generate the coalescence. The GMAW electrode is a small diameter wire having very long length that is wound in a wire-pool. During welding, this wire electrode is continuously fed to the welding zone to supply required filler metal to fill the root gap. Composition of the electrode metal is chosen based on the base metal – usually electrode has similar composition with that of base metals (as GMAW is preferred for homogeneous welding). Because GMAW uses a bare electrode, shielding gas from a separate source must be supplied to the welding zone to protect the hot weld bead from oxidation and contamination. In the GMAW process, the shielding gas might be inert or a blend of active and inert gases. Based on the composition of shielding gas, GMAW process can be classified into two groups – Metal Inert Gas (MIG) welding and Metal Active Gas (MAG) welding.

4.4.1 Difference between MIG and MAG

In Metal Inert Gas (MIG) welding, inert gas (such as argon, helium, nitrogen, or a combination of these gases) is used for shielding purposes. Metal Active Gas (MAG) welding, on the other hand, uses a blend of active and inert gas for shielding. Oxygen and carbon dioxide are two commonly used active gases for MAG welding. Such gases can disintegrate during welding due to extreme heat of the arc and can therefore induce

chemical elements into the weld bead. Thus, MAG welding gives the provision to alter chemical and mechanical properties of the weld bead. Few other benefits like deep penetration, stable arc, low spatter, etc. can also be harnessed in specific cases with the usage of active gases. It is worth mentioning that both MIG and MAG welding processes are carried out in same way; the only difference lies in the composition of shielding gas and the consequent influences.

4.4.2 GMAW Operating Modes

Gas Metal Arc Welding (GMAW) has four different operating modes (droplet transfers): short-circuiting, globular, spray, and pulsed. The operating mode is determined by the current level, voltage, and oxidizing potential of the shielding gas.

4.4.2.1 Short-circuiting

Short-circuiting transfer is used in CO₂ shielding at low current levels. Consequently, short-circuiting has very low heat input and penetration. This is beneficial for welding over impurities, filling gaps, and minimizing distortion in thin sections. It can be used in any position because of the fast-freezing puddle. Short-circuiting should not be used on thick sections because it may risk in “lack of fusion.”

4.4.2.2 Globular Transfer

Globular transfer is a form of short-circuiting that uses a higher current. Because the arc in globular transfer does not go out like it does in short-circuiting, there is more heat input and better penetration. It will run on 100 percent CO₂ or a mixture of argon and CO₂.

4.4.2.3 Spray Transfer

Spray transfer commonly uses a gas mixture of 98% argon and 2% oxygen. Spray transfer uses a high current level, which results in rapid penetration and deposition. 1/16-inch wire can provide adequate penetration and a deposition rate of 14 pounds per hour in the spray mode. Spray transfer can only be used in a horizontal and flat positions.

4.4.2.4 Pulsed Transfer

Pulsed transfer is a hybrid or mixed method of spray and globular transfer. There is a low background current and a high pulse current. The high current causes a spray transfer,

and the welding machine then reduces the current to a safe level. Because the heat input is less than spray transfer, it can be used to weld out of position. Penetration is not an issue because the heat input is greater than that of a short-circuit. The mechanical properties of the weld metal are generally very good since the arc is totally shielded (as with minimum oxygen concentration) and there is no slag system.



Figure 55. Gas Metal Arc Welding (MIG)

4.5 Gas Tungsten Arc Welding (TIG)

Tungsten Arc Welding (TIG) is the most expensive and high-quality arc welding technique. Although it is primarily done by hand, several automated applications are available. A skilled welder can drop 12 pounds of weld metal each hour at a rate of 1 to 3 inches per minute. The heat input per inch of weld can be quite high due to the slow travel speed, resulting in good weld metal fusion. However, thin sections may get deformed.

The heat input per deposited weld metal is low because manual gas tungsten arc welding operates at low amps and voltages, and cold filler metal is introduced to the puddle. This gives finer grain size and much better mechanical properties than other processes. There are no micro-inclusions to degrade mechanical properties because there is no flux. Pure argon is generally used as the shielding gas on carbon and stainless steels resulting in a very low oxygen level in the weld metal, resulting in good mechanical qualities.



Figure 56. Gas Tungsten Arc Welding (TIG)

4.6 Types of Welding Operations

4.6.1 Manual Welding

Welding whereby the entire welding operation is performed and controlled by hand. Since the welder does all the work manually, it requires considerable skill to maintain continuous control, physically demanding and can lead to injuries.

A light manual welding machine has one of the lowest capacities among all types of welding machines. Its capacity ranges in between 100 to 200A. This machine is portable and is best suited for light welding processes.

Examples: SMAW and TIG

4.6.2 Semi-Automatic Welding

In semiautomatic welding, defined as “manual welding with equipment that automatically controls one or more of the welding conditions,” the welder manipulates the welding gun to create the weld while the electrode is automatically fed to the arc.

Examples: FCAW, GMAW (MIG, MAG)

4.6.3 Machine Welding

In mechanized welding, the welder’s intervention consists of adjusting the equipment controls in response to visual observation of operations. The torch, gun, or electrode holder is held by a mechanical device, which can be a robotic operation.

In fully automated welding, the equipment needs only occasional or no observation of the weld, and no manual adjustment of equipment controls. The welder's involvement is limited to activating the machine to initiate the welding cycle and observing the welds for defects on an intermittent basis. Automatic welding using a robot that can be pre-programmed to different welding paths and fabrication geometries.

An automatic welding machine has a high amount of capacity. Its capacity ranges in between 800 to 300A. This type of machine is not portable and is suitably used for heavy welding processes.

Example: SAW

4.6.4 Which of these processes is "The Best"?

Each arc welding process has its own set of benefits and drawbacks. Each can generate high-quality welds, but if not used appropriately, they can also produce defective welds. In general, gas shielding results in purer weld metal with better mechanical properties. Fluxed methods are easier to use, however they can cause micro-inclusions, higher oxygen levels, and poor mechanical characteristics.

Successful application of mechanized/automated systems can offer several advantages. These include increased productivity, consistent weld quality, predictable welding production rates, reduced variable welding costs and lower part costs. Limitations include higher capital investment than for manual welding equipment, a need for more accurate part location and orientation, and more sophisticated arc movement and control devices. As such, production requirements must be large enough to justify the costs of equipment and installation, the maintenance of equipment and the training of operators/programmers for automated/robot equipment.

And so, depending on the application, intended cost, and required quality level, any of the above methods could be "the best" if used correctly.

5 CHAPTER - 5 WELDING DEFECTS AND DISCONTINUITIES

Any discontinuity (or irregularity) in the weld metal, which exceeds the applicable code limit, is termed as a weld defect or welding defect. Please keep in mind that a discontinuity is an interruption in the typical physical structure of a material that sharply changes its

properties. A simple variation of properties does not characterize a discontinuity. A discontinuity can only be deemed a defect if it exceeds the given code limit, therefore every defect in the weld metal is a discontinuity, but not every discontinuity in the weld metal is a defect. In short, a weld defect is any flaw or imperfection that compromises the intended use of a weldment.

Defects may occur due to the following reasons.

- a. Incorrect welding parameters
- b. Inappropriate welding procedures
- c. Poor process condition
- d. Inappropriate selection of filler metal and parent metal
- e. Unskilled welder or welding operator
- f. Incorrect job preparations

5.1 Classification of Defects

Defects can be classified as external defect (also known as visual defect or surface defect) or internal defect (also known as hidden defect or subsurface defect). External defects are those that are visible on the surface. Internal defects are those that are present at a deeper level in the material and are not visible on the surface of the product.

The weld defects are classified according to ISO 6520 and the acceptable limits are specified in ISO 5817 and ISO 10042.

Broadly, there are 10 common defects.

1. Cracks
2. Incomplete penetration
3. Lack of fusion
4. Undercut
5. Porosity and blowholes
6. Spatter
7. Overlap
8. Inclusions
9. Warpage

10. Burn Through

Different types of welding defects along with their causes and remedies are explained below.

5.2 Cracks

It's the most dangerous of all the flaws. Cracks can be microscopic or macroscopic, and they can be of any size or shape. Cracks may appear in the zone affected by the weld (fused zone or heat affected zone) on the surface, beneath the surface, at any depth, or at the root. The crack occurs when localized stress exceeds the ultimate Tensile Stress (UTS) of the material. It may propagate within the material.



Figure 57. Crack

Cracks are of two types.

- a. Hot Cracks
- b. Cold Cracks

5.2.1 Hot Cracks

Hot cracks form as weld begin to solidify and are caused by brittle constituents (presence of Sulphur, carbon, silicon and hydrogen). Hot cracks mostly occur in the weld metal, although they can also form in the Heat Affected Zone (HAZ).

When a hot crack occurs on the weld metal, then it is termed as Solidification Crack and if it occurs in the HAZ then called Liquation crack.

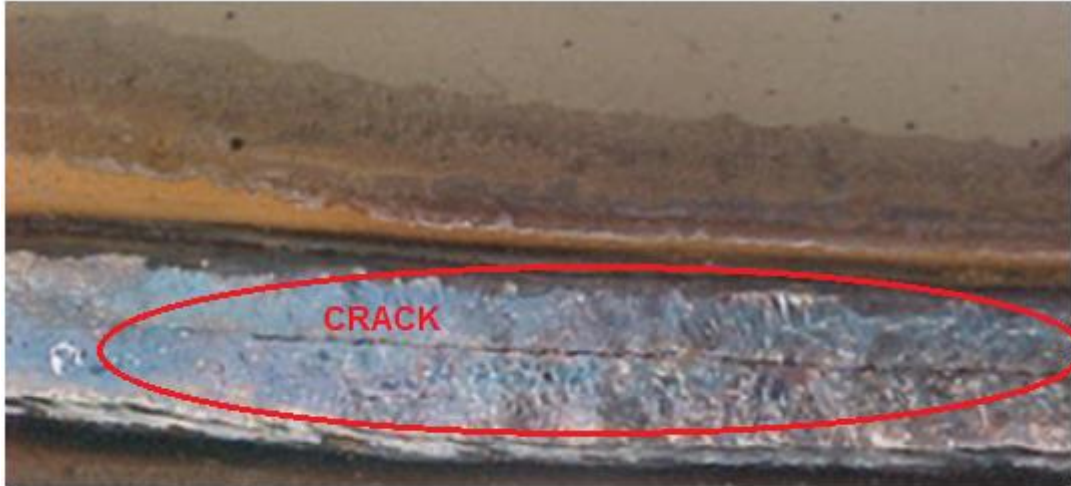

Figure 58. Hot Cracks

The long centerline crack is Solidification Cracking (hot crack) can occur when the depth-to-width ratio of the solidifying weld bead is large (deep & narrow). Refer figure above.

5.2.1.1 Causes of Hot Crack

- a. High concentration of residual stress
- b. Rapid cooling of the molten weld pool
- c. High thickness of base material
- d. Poor ductility of welded material
- e. High welding current
- f. Inadequate heat treatment

5.2.1.2 Prevention

- a. More uniform heating and slower cooling
- b. Using right filler metal

5.2.2 Cold Cracks

Cold cracks appear under room temperature after the weld metal has solidified; they can appear several days after the welding has been completed. It usually forms in the HAZ, but it can also happen on the weld metal. It's frequently linked to non-metallic inclusions.

5.2.2.1 Causes of Cold Crack

Diffusion of Hydrogen atoms: Cold cracking is caused by the diffusion of hydrogen atoms. These hydrogen atoms may be induced in the weld metal from the surrounding, electrode, base metal, or any contamination present on the root face.

Insufficient Preheating: Microstructural alterations may occur as a result of inadequate preheating. Microstructural crystals have the potential to restructure and create martensite. Cracks are common in martensite. Preheating also helps in the diffusion of hydrogen atoms and ensures that the joint is free of moisture prior to welding.

5.2.2.2 Prevention

- a. Proper preheating
- b. Use of low hydrogen electrodes

5.2.2.3 Star Crack (or Crater)

A hot crack that develops at the crater on the weld metal is known as a star crack. A crater is a depression on the weld bead that forms when the arc breaks or the electrode is changed.

It develops when the center of the weld pool solidifies before the rest of the pool, causing the center to pull the outer weld, resulting in star cracks.

5.3 Porosity

Porosity is the presence of pockets that do not contain any solid material. The pocket contains gas bubbles in the molten weld pool. These trapped gases are unable to escape the molten weld pool, resulting in porosity or blowholes. Porosity refers to a small pore or void, whereas blowholes are larger holes or cavities.

Porosity can be found on the surface of the weld metal or within it. Porosity can occur alone or more commonly in clusters.

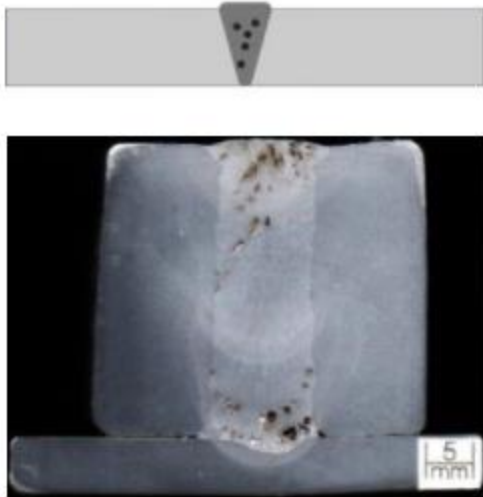

Figure 59. Porosity

Porosity may be due to excessively high current or longer arc length or due to poor welding procedure. Porosity results in stress concentration and reduced ductility of metal.

Porosity differ from slag inclusions in that the pockets contain gas rather than a solid. Hydrogen, carbon monoxide, carbon dioxide, nitrogen, and oxygen are the most common gases that become trapped and produce porosity. These gases are formed due to the fluxes on the welding electrode, moisture, oil, grease, and other foreign impurities on the joint or on the welding electrode, and filler wire. Porosity is also caused by a lack of shielding gas flow in GMAW, FCAW, GTAW, and PAW welding processes.

5.3.1 Prevention

- a. Use low Hydrogen electrode
- b. Baking of electrodes before welding as per the recommended procedure
- c. Thorough cleaning of the joint surface and adjacent area before welding
- d. Preheat the joint before welding
- e. Ensure sufficient flow of shielding gases if using TIG or MIG welding
- f. Correct the flow of the protection gas and to use gases of greater purity in its composition

5.4 Undercut

Undercutting is the burning away of the base metal at the toe (edge) of the weld. This results in groove in base metal adjacent to toe of weld and left unfilled by weld metal

during welding process. Undercutting may result in loss of cross section and will act as stress riser during fatigue loading. This defect may be due to excessive current or longer arc length. It can be easily detected visually and can be corrected by depositing additional weld material.

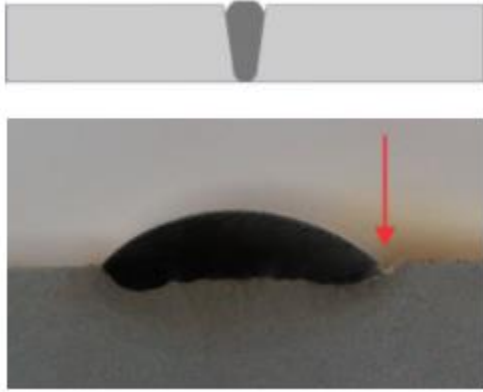

Figure 60.Undercut

5.4.1 Causes of Undercut

- a. High welding current
- b. Arc gap that is too long
- c. Large electrode diameter
- d. Incorrect electrode angle

5.4.2 Prevention

Reduce the current or reduce the welding speed.

5.5 Underfill

When the weld metal surface remains below the adjacent surface of the base metal then it is called an underfill. Basically, Underfill is undersized welding.

5.6 Incomplete Penetration

Incomplete Penetration or lack of penetration occurs when the weld metal does not entirely reach the root of the joint and as a result the filler and the base metal are not fused at the root of the joint. The frequent cause of incomplete penetration is a joint design which is not suitable for the welding process or the conditions of construction.

This defect is commonly found in groove welds due to unsuitable groove design for selected welding process and is the most detrimental fault because it acts as a stress raiser, which means a crack may originate or spread from here. It has the severe effect on the load-bearing capacity of a weld.

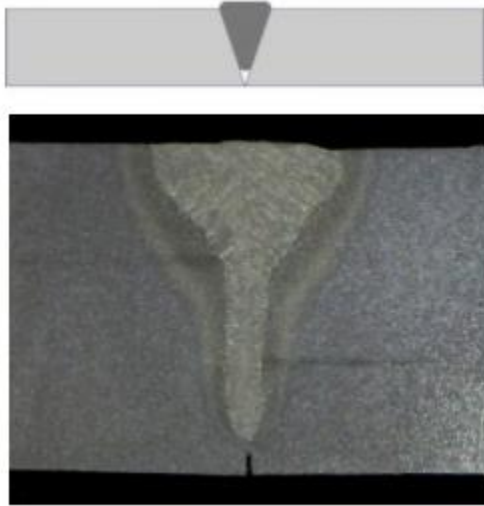

Figure 61. Incomplete Penetration

5.6.1 Causes of Lack of Penetration

- a. Root opening is too small
- b. The included angle of a V-groove is too small
- c. The electrode is too large.
- d. Fast travel speed
- e. Low heat input
- f. The welding current is too low.

5.6.2 Prevention

- a. Proper joint preparation (may require changing the joint geometry)
- b. Proper heat input (may require increasing the current)
- c. Correct travel speed (may require decreasing the welding speed)
- d. Using electrode of suitable size
- e. Lack of penetration can be repaired by proper back gouging.

5.7 Lack of Fusion (Incomplete Fusion)

It's due to a lack of proper melting (or fusion) between the weld metal and the base metal, or between one layer of the weld and the other. Cold lapping or cold shuts are terms used to describe the lack of fusion.

Incomplete fusion may result if surfaces to be jointed have not been cleaned properly and are coated with oxides and other foreign materials. Insufficient current supplied by welding equipment and high rate of welding will result in incomplete fusion.

Lack of fusion is an internal defect, but it can also occur on the external surface if the parent metal's sidewall does not correctly fuse with the base metal.

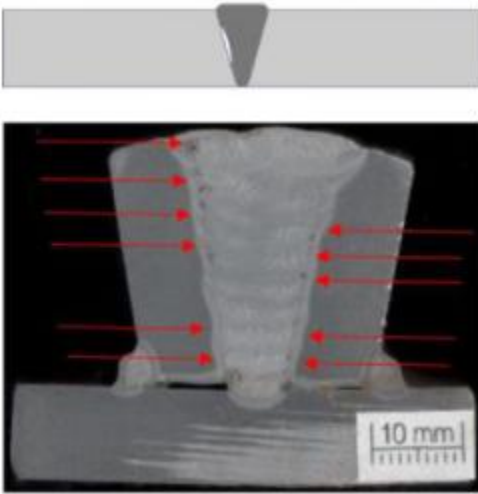

Figure 62. Lack of Fusion

5.7.1 Causes of Lack of Fusion

- a. Low welding current
- b. Travel speed too high or too low
- c. Unfavorable heat input
- d. Linear misalignment
- e. Incorrect tilt angle
- f. Differing root face widths
- g. Dirty plate surfaces.

5.7.2 Prevention

To correct this discontinuity, you can increase the current, decrease the welding speed, change the joint geometry, or use some artifice to avoid magnetic blowing.

5.8 Spatters

Spatters are small globular metal droplets (of weld metal) splashed out on the base metal during welding. Spatters stick on the base metal therefore can be removed by wire brush or buffing.

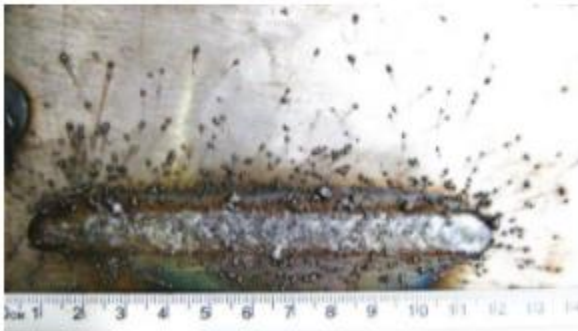

Figure 63. Spatters

5.8.1 Causes of Spatters

- a. Excessive arc current
- b. Excessive long arc
- c. Improper shielding gases
- d. Electrode with improper flux
- e. Damp electrodes

5.8.2 Prevention

To correct this discontinuity, one can reduce the current and control the instability in the metal transfer.

5.9 Overlap

Overlap occurs when the weld face extends far over the weld toe. During welding, molten metal overflows on the base metal without fusing with the base metal.



Figure 64.Overlap

5.9.1 Causes of Overlap

- a. Current too low
- b. Using large electrodes
- c. Large deposition in a single run
- d. Longer arc
- e. Slow arc travel speed

5.10 Excessive Penetration

Excessive penetration occurs when the penetration of weld metal through the joints is too high. It acts as a notch where stress concentration takes place. Furthermore, it results in wastage too.

5.10.1 Causes of Excessive Penetration

- a. Too wide a root gap
- b. High welding current
- c. Slow travel Speed

5.11 Inclusion

Inclusion is any entrapped solid materials (either metallic or non-metallic) in the weld metal. Foreign elements such as tungsten, oxides, slag, and flux are commonly entrapped in the molten weld pool and produce inclusions.

Inclusion can happen in any fusion welding technique, but it's most common in flux shielded arc welding processes like Shielded metal arc welding (SMAW), Flux core arc welding (FCAW), and Submerged arc welding (SAW).

Tungsten inclusion occurs in those welding processes which use “Tungsten” as electrodes such as TIG welding and Plasma Arc Welding (PAW)

Inclusions are of four types, these are:

- a. Tungsten Inclusion
- b. Oxide Inclusion
- c. Slag Inclusion
- d. Flux Inclusion

Slag Inclusion occurs when slag gets entrapped and is unable to escape from the molten weld pool.



Figure 65. Inclusion

Tungsten Inclusion (in TIG welding or Plasma Arc Welding - PAW) occurs when tungsten droplets become entrapped within the weld metal.

Oxide Inclusion occurs when surface oxides get entrapped.

Flux and slag are commonly used interchangeably; however, they are not the same thing. Flux is an electrode coating (a solid material that covers the electrode), whereas Slag is a byproduct of the reaction between flux and the molten weld pool metal.

Inclusion acts as a stress raiser hence should be avoided.

5.11.1 Causes of Inclusion

Inadequate cleaning of weld surface between passes. It can also occur in single pass welds when slag gets trapped in the root and toes of the weld.

5.12 Wagon Tracks

Wagon tracks are slag inclusions that run parallel to the weld axis. During root pass, a groove is formed at the toe, due to wrong welding techniques, and that groove is filled by slag (especially Hydrogen which has been trapped by the solidified slag) and thus wagon tracks are formed. It is also known as worm tracks.

5.13 Warpage

Warpage is an unwanted distortion in the shape and position of the metal parts. It happens when the heat usage is wrong and is caused by the contraction/expansion of the welded parts.



Figure 66. Warpage

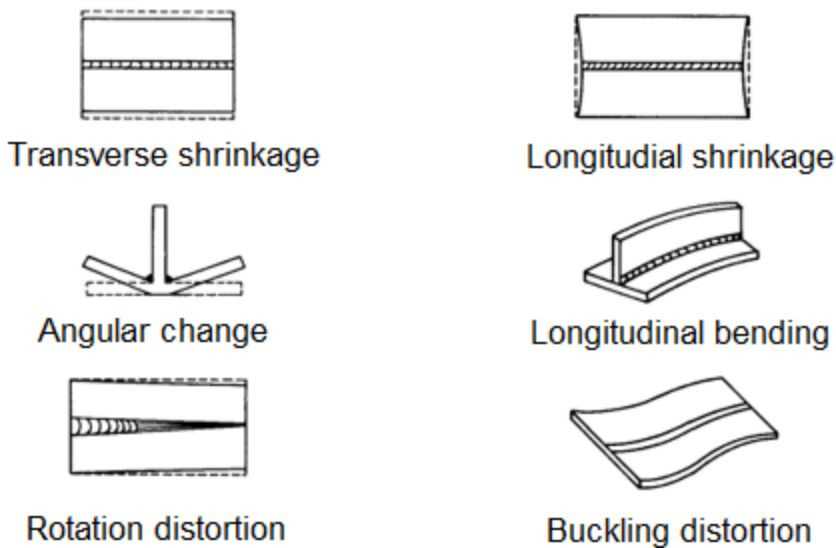

5.14 Burn Through

Burn through is a collapse of the weld pool resulting in a hole in the weld.

This is a common discontinuity when welding thin parts. It happens when the root opening is too large or current is too high.

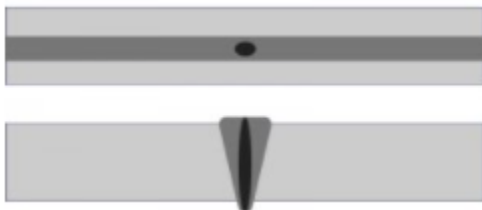

Figure 67. Hole caused by Burn Through



Figure 68. Burn Through

5.14.1 Causes

- a. Travel speed is too slow
- b. Current is too high
- c. Excessive grinding of root face
- d. Excessive root gap

With the purpose of approving a weld, several techniques are carried out to find out and prove the absence of defects that put the welded structure at risk. Unlike destructive tests (DT), non-destructive tests (NDT) aim at the possibility of observing discontinuities without compromising the welded part, being carried out in the stages of manufacture, construction, assembly, and maintenance.

6 CHAPTER - 6 WELD QUALITY CONTROL AND WPS

Welding design depends highly on a thorough understanding of the expected stress conditions and required service life. Welding distortion and residual stress are frequently critical design issues since excessive amounts of either might affect whether the weldment is satisfactory.

6.1 Welding Quality Objectives

The following are typical quality requirements for weld products.

- a. The product is finished to the exact dimensions specified in the design.
- b. The product has the necessary functionality, durability, and strength.
- c. The product exhibits a smooth, uniform, and consistent appearance.

6.2 Importance of Weld Design

- a. Proper weld design and testing ensures that welds do not fail under their intended load and environmental conditions
- b. The proper base materials must be chosen (and filler metals when applicable)
- c. Appropriate weld strength requirements must be met
- d. Weld toughness and ductility targets must be established
- e. Fatigue resistance against cyclic loading must be considered

6.3 Characteristics of a Good Weld

- a. The bead has no cracks or holes.
- b. The bead has uniform waves, width, and height.
- c. The finished product meets the design specifications and is practically distortion-free.
- d. The welding meets the required strength.
- e. Penetration - the amount of fusion into the parent material - is important since it impacts the weld's cross-sectional strength and thus its load-bearing capacity in service.

6.4 Codes and Standards

Almost all design, welding, fabrication, material, repair, testing, and inspection requirements are covered under three main governing organizations in USA. These main organizations are:

- a. The American Welding Society (AWS)
- b. The American Society of Mechanical Engineers (ASME)
- c. The American Petroleum Institute (API)

All these organizations have multiple specific codes for various types of construction, processes, and/or materials. Design specifications and approved materials are included in these codes.

6.4.1 American Welding Society (AWS)

The AWS publishes numerous codes, specifications, recommended practices, classifications, methods, and guides related to welding.

These documents include such general subjects as welding definitions and symbols, classification of filler metals, qualification and testing, welding processes, welding applications, and safety.

Refer to Annexure-1 for more details.

6.4.2 American Society of Mechanical Engineers (ASME)

This society is responsible for the development of the Boiler and Pressure Vessel Code, which contains eleven sections and covers the design, construction, and inspection of boilers and pressure vessels. ASME also produces the Code for Pressure Piping, which consists of seven sections. Each section prescribes the minimum requirements for the design, materials, fabrication, erection, testing and inspection of a particular type of piping system. Both documents are American National Standards.

Refer to Annexure-1 for more details.

6.4.2.1 National Board of Boiler and Pressure Vessel Inspectors (NBBPVI)

Often referred to as the National Board, represents the enforcement agencies empowered to assure adherence to ASME B&PVC

Involved in boiler and pressure vessel registration and investigation of possible Code violations

Publishes National Board Inspection Code (NBIC) that describes maintenance, inspection, and repair requirements

Boiler and pressure vessel repair, governed by the “R” stamp is also under their jurisdiction

6.4.3 American Petroleum Institute (API)

The most well-known is possibly API Std 1104 – Standard for Welding Pipelines and Related Facilities.

Refer to Annexure-1 for more details.

6.4.4 What do Codes & Standards Provide?

Welding codes and standards are often used by the welding fabricator to assist with the development of their process control system. The specific content and requirements of a welding code or standard can vary in detail, however, there are three key elements which are common.

- a. The first requirement for process quality control is documented procedures defining the manner of production. For welding, this is the welding procedure specification (WPS). The document provides the essential variables such as the welding process, type and thickness of base metal, filler metal type, electrical parameters, joint design, welding position, and others.
- b. A second requirement is criteria for workmanship. For welding, this may be the code or standard acceptance criteria. It may contain information and requirements on such items as base materials, welding consumable classification requirements, shielding gas quality, heat treatment requirements, preparation and care of base material, and other welding fabrication requirements.
- c. A third requirement is qualification of personnel. This may be addressed by the welder performance qualification.

Regardless of the manufacturer's overall quality system, there may be opportunities available through the selection and use of an appropriate welding code or standard for welding quality and reliability improvements.

6.5 Weld Quality Control and Inspection

Weld quality control and inspection begins long before the first welding arc is struck. The inspector must go over the job package to familiarize himself with the following:

- a. Welding processes to be used
- b. Materials and any special properties
- c. Joint configurations and preparation
- d. Welding procedure specifications (WPS) to be used and any limitations
- e. Qualifications of welders to be used and any limitations
- f. Heat treatment (pre-heat or post weld) if any
- g. Nondestructive examination (NDE) if any
- h. Specific ASME code requirements (for example, Section VIII, Div.1, lethal service).

Before a welded joint can be made on a project, it must be proven that the weld can be made using the desired materials and attain the required strength and ductility. Once the joint has been proven, a welding procedure specification (WPS) that details how the weld is to be made is published and the procedure is considered to be prequalified. If the engineer specifies a joint or weld that has not been prequalified, it is necessary for the welders to go through the qualification process to develop a new qualified welding procedure.

6.5.1 Welder Certification

A good quality control program will have procedures in place to ensure that welds are of appropriate quality.

The welding inspector should have a basic understanding of:

- a. Welding processes
- b. Nondestructive testing methods
- c. Codes and standards

Welder qualification tests are designed to test the welder's skill. The certification process requires the welder to create the weld on a sample using the materials, procedure, and position that will be used for making the final connection. The sample is tested to ensure that it meets specifications. Once a welder demonstrates that he/she can consistently create a weld that meets performance specifications then they are certified to make that particular weld.

The certified Welding Inspector should have the skills required to review the Procedure Qualification Record (PQR) and a Welding Procedure Specification (WPS). The WQTR (Welder Qualification Test Record) is a record that shows the welder has the understanding and ability of a specific welding condition.

6.6 Welding Procedure Specification (WPS)

The WPS (Welding Procedure Specification) is a written document that contains all the information needed to make production welds that meet code criteria. The WPS (Welding Procedure Specification) is developed for each welding type, supported by a PQR (Procedure Qualification Record) to ensure producing a good weld.

The following are the brief details on the information contained in WPS.

6.6.1 Basic Information

All the basic information about the welding procedure:

- a. Name of the company and person who developed it
- b. Specification number and date
- c. Most WPS will be backed on a PQR (Procedure Qualification Record), you should refer to it to make it easy to trace the document back.
- d. Number and date of the last revision
- e. Welding processes and type

Company Name	_____	By:	_____
Welding Procedure Specification No.	_____	Date:	_____
Revision No.	_____	Supporting PQR No.(s)	_____
Date	_____		
Welding Process(es)	<u>SMAW</u>	Type (s)	<u>Manual</u>

Figure 69. Basic information about welding procedure

6.6.2 Joints

Details of the joint design, including root spacing and backing (if the joint needs it and the backing material). This information should feature a graphic representation of the joint to make it easier for the welder.

JOINTS (QW-402)		Details		
Joint Design	See permitted figures (right) or per constr. dwg			
Root Spacing	<input type="checkbox"/>			
Backing (Yes)	<input type="checkbox"/> Yes	<input type="checkbox"/> (No)	<input type="checkbox"/> Yes	
Backing Material (Type)	Material or Weld Metal			
	(refer to both backing and retainers)			
<input type="checkbox"/> Metal	<input type="checkbox"/> Nonfusing Metal			
<input type="checkbox"/> Nonmetallic	<input type="checkbox"/> Other			
<p>Sketches, Production Drawings, Weld Symbols or Written Description should show the general arrangement of the parts to be welded. Where applicable, the root spacing and the details of weld groove may be specified.</p> <p>(At the option of the Mfgr., sketches may be attached to illustrate joint design, weld layers and bead sequence, e.g., for notch toughness procedures, for multiple process procedures etc.)</p>				
		FIG A (BUTT JOINT)	FIG B (CORNER JOINT)	FIG C (EDGE JOINT)
				
		FIG D (LAP JOINT)	FIG E (TEE JOINT)	
<input type="checkbox"/> Other (Describe)	<input type="checkbox"/>			
	<input type="checkbox"/> Figure A	<input type="checkbox"/> Figure B	<input type="checkbox"/> Figure C	<input type="checkbox"/> Figure D
			<input type="checkbox"/> Figure E	

Figure 70. Details of Joint Design

6.6.3 Base and Filler Metals

Information about the base and filler metals that are going to be used in the welding procedure. You should specify the weld type (fillet or groove) and the thickness range of the base metal.

*BASE METALS (QW-403)			
P-No.	_____	Group No.	_____ to P-No. _____ Group No. _____
OR			
Specification type and grade	_____	to Specification type and grade	_____
OR			
Chem. Analysis and Mech. Prop.	_____	to Chem. Analysis and Mech. Prop.	_____
Thickness Range:			
Base Metal:	_____	Groove	_____ Fillet _____
Other	_____		
Maximum Pass Thickness $\leq 1/2$ inch (13 mm) (Yes) <input type="checkbox"/> (No) <input type="checkbox"/>			
*FILLER METALS (QW-404)			
Spec. No. (SFA)	_____	_____	_____
AWS No. (Class)	_____	_____	_____
F-No.	_____	_____	_____
A-No.	_____	_____	_____
Size of Filler Metals	_____	_____	_____
Filler Metal Product Form	_____	_____	_____
Supplemental Filler Metal	_____	_____	_____
Weld Metal	_____	_____	_____
Thickness Range:			
Groove	_____	_____	_____
Fillet	_____	_____	_____
Electrode-Flux (Class)	_____	_____	_____
Flux Trade Name	_____	_____	_____
Consumable Insert	_____	_____	_____
Other	_____	_____	_____

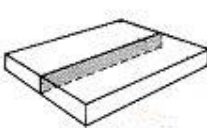
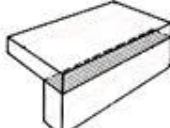
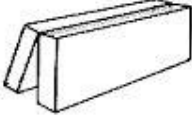
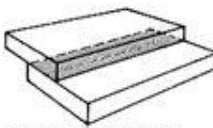
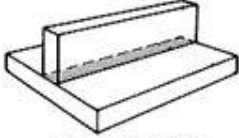
Figure 71. Information about the base and filler metals to be used in the welding procedure

6.6.4 Additional details

Pre and post weld heat treatment required, gas used and the positions in which the procedure will be performed. The welding progression should be specified if it is required.

POSITIONS (QW-405) Position(s) of Groove _____ Welding Progression: Up _____ Down _____ Position(s) of Fillet _____	POST WELD HEAT TREATMENT (QW-407) Temperature Range _____ Time Range _____																
PREHEAT (QW-406) Preheat Temp. Min. _____ Interpass Temp. Max. _____ Preheat Maintenance _____ (Continuous or special heating where applicable should be recorded)	GAS (QW-408) Percent Composition <table border="1" style="width: 100%; border-collapse: collapse;"> <thead> <tr> <th></th> <th>Gas(es)</th> <th>(Mixture)</th> <th>Flow Rate</th> </tr> </thead> <tbody> <tr> <td>Shielding</td> <td>_____</td> <td>_____</td> <td>_____</td> </tr> <tr> <td>Trailing</td> <td>_____</td> <td>_____</td> <td>_____</td> </tr> <tr> <td>Backing</td> <td>_____</td> <td>_____</td> <td>_____</td> </tr> </tbody> </table>		Gas(es)	(Mixture)	Flow Rate	Shielding	_____	_____	_____	Trailing	_____	_____	_____	Backing	_____	_____	_____
	Gas(es)	(Mixture)	Flow Rate														
Shielding	_____	_____	_____														
Trailing	_____	_____	_____														
Backing	_____	_____	_____														

Figure 72. Information about pre and post weld heat treatment required, gas used and the positions in which the procedure will be performed

6.6.5 Electrical Characteristics

Information about each weld pass, including:

- a. Process
- b. Filler metal classification and diameter
- c. Current type and polarity
- d. Amps range
- e. Wire feed speed range
- f. Energy of power range
- g. Volts range
- h. Travel speed range
- i. Other electrical specifications

6.6.5.1 Technique

- a. String or weave bead
- b. Orifice, nozzle or gas cup size
- c. Initial and interpass cleaning
- d. Method of back gouging
- e. Oscillation
- f. Contact tube to work distance
- g. Multiple or single pass (per side)
- h. Multiple or single electrodes
- i. Electrode spacing
- j. Peening
- k. Other

6.7.1 Procedure Qualify Record (PQR)

A PQR is a record of the welding data used to weld a test coupon. It also contains the test results of the tested specimens.

6.7.2 Test Coupon

A weld assembly for procedure or performance qualification testing. The coupon may be any product from plate, pipe, tube, etc., and may be a fillet weld, overlay, deposited weld metal, etc.

6.7.3 Test Specimen

A sample of a test coupon for specific test. The specimen may be a bend test, impact test, chemical analysis, macro test, etc. A specimen may be a complete test coupon, for example, in radiographic testing or small diameter pipe tension testing.

6.7.4 Preheating

Pre-heating of joints help to reduce heat affected zone cracks but increases the cost of welding. It is done to remove surface moisture in highly humid conditions, to disperse hydrogen away from weld pool and heat affected zone, to bring steel to ambient temperature in cold climates.

Preheat is needed in general for carbon content higher than 0.30% or for Hardness equal to or higher than 30 HRC. Post Weld Heat Treatment (PWHT) may be needed too in those cases.

6.7.5 Post Weld Heat Treatment (PWHT)

Post weld heat treatment (PWHT) is used to change the properties of the weld metal, controlling the formation of crystalline structures.

6.7.6 Filler Material

When welding two pieces of metal together, we often have to leave a space between the joint. The material that is added to fill this space during the welding process is known as the filler material (or filler metal). When choosing filler metals, finding those with the right mechanical and chemical properties for the application is critical. Correct properties not

only ensure the proper weld strength but may also help prevent costly complications. Here are some rules:

- a. When welding together two steels of different strength it is recommended to select a filler matching the strength of the weaker of the two. The lower strength filler metal would provide such benefits as better ductility, improved weld ability, and lower cost.
- b. For high strength steels one should specify low hydrogen filler metals to reduce susceptibility to cracking.
- c. In applications that are subjected to rapid or cyclic loads, severe service temperatures, or other stresses that compromise the weld's integrity—such as seismic activity—using a filler metal exhibiting minimum Charpy V-notch (CVN) test value at given temperatures is extremely important.
- d. If stress relieving is required, it may reduce the weld strength. To maintain the strength required from the structure, one may need to use low alloy steel filler metals instead of low carbon steel.

The American Welding Society (AWS) A5 filler metal criteria are used by most filler metal manufacturers to create, classify, and produce filler metals. These standards detail the minimum impact toughness requirements for each filler metal classification, as well as the testing procedure for these electrodes.

Filler metal categories can be chosen depending on the code or specification requirements for your application. The AWS D1.8 Structural Welding Code—Seismic Supplement, for example, was created to aid in the safety of demand-critical applications such as structures built in seismic zones. Be careful that code or specification requirements may exceed the toughness requirements given in a filler metal specification.

6.7.7 Welding Rod

The term welding rod refers to a form of filler metal that does not conduct an electric current during the welding process

6.7.8 Electrode

In electric-arc welding, the term electrode refers to the component that conducts the current from the electrode holder to the metal being welded. Electrodes are classified into two groups: consumable and non-consumable.

- a. Consumable electrodes not only provide a path for the current, but they also supply filler metal to the joint. An example is the electrode used in shielded metal-arc welding.
- b. Non-consumable electrodes are only used as a conductor for the electrical current, such as in gas tungsten arc welding. The filler metal for gas tungsten arc welding is a hand fed consumable welding rod.

6.7.9 Flux

Before performing any welding process, the base metal must be cleaned from impurities such as oxides (rust). Unless these oxides are removed by using a proper flux, a faulty weld may result. The term flux refers to a material used to dissolve oxides and release trapped gases and slag (impurities) from the base metal such that the filler metal and the base metal can be fused together. Fluxes come in the form of a paste, powder, or liquid. Different types of fluxes are available, and the selection of appropriate flux is usually based on the type of welding and the type of the base metal.

7 CHAPTER -7 WELD INSPECTION AND TESTING

Welding inspection is the use of examination methods to ensure that welded joints fulfill quality standards and are fit for purpose. A range of welding inspection techniques may be applied, depending on factors such as joint configuration, specific defects of interest, material type/thickness and whether in shop or on site.

7.1 Weld Properties

From a weld design standpoint, it is important to understand the mechanical properties of welds. Some of the important properties of a weld include:

- a. Strength – the ability to withstand an applied load
- b. Ductility – the ability to deform/stretch without failing
- c. Hardness – the ability to resist indentation
- d. Toughness – the ability to absorb energy
- e. Soundness – freedom from imperfections
- f. Fatigue strength – resistance to failure under repeated loads

7.2 Testing and Inspection Methods

A weld inspection is carried out using a destructive testing (DT) or nondestructive testing (NDT).

- a. Destructive Testing (DT): Destructive weld testing is a weld testing technique that involves the destruction of the completed weld physically to evaluate its properties.
- b. Nondestructive Testing (NDT): Nondestructive testing is the process of inspecting, testing, or evaluating materials, components or assemblies for discontinuities, or differences in characteristics without destroying the serviceability of the part or system.

7.3 Destructive Testing

Destructive weld testing, as the name suggests, involves the physical destruction of a completed weld to evaluate its strength and characteristics. These tests are mainly carried out to the specimen's failure, to evaluate a specimen's performance or material's behavior under different loads. These tests are much easier to carry out, give more information, and are easier to interpret than non-destructive tests.

ANSI/AWS B4.0 is an American national standard for the mechanical testing of welds, which covers a wide variety of tests including tension tests, shear tests, bend tests, fracture toughness tests, hardness tests, and others. This standard extensively references ASTM test methods such as ASTM E8 and specifies how to use these test methods when assessing weldments. Some of the most common methods for executing a destructive weld testing are:

- a. Macro etch testing
- b. Fillet weld break test
- c. Transverse tension test
- d. Guided bend test

7.4 Macro Etch Testing

This method requires the removal of small samples from the welded joint. These samples are then polished at their cross section and etched using a mild acid mixture, depending on the base material used. The acid etch provides a clear visual of the weld's internal structure.

Inspection of the etched sample reveals depth of penetration, as well as evidence (if any) of lack of fusion, inadequate root penetration, internal porosity, and cracking shown at the fusion line (which is the transition between the weld and the base material).

This type of inspection is a snapshot of the overall weld-length quality when used for sampling inspection of production welds. Macro etch testing is also used successfully in failure analyses to pinpoint welding problems such as crack initiation.

7.5 Fracture Test

Weld fracture test is performed to reveal embedded imperfections such as lack of fusion, incomplete penetration, cracking due to inadequate width to height ratio, slag inclusions and porosity.

Two commonly known fracture tests are nick break test and fillet break test.

7.5.1 Nick Break Test

Nick break test is used to detect any internal defects like slag inclusions, poor fusion, gas pockets, oxidized metal, and burnt metal in the welded butt joint.

The test involves taking a sample from the welded joint by either machining or cutting by oxy-acetylene torch. Every edge of the joint is given a slot by a saw cut through the center. The prepared piece of the specimen is bridged across the two steel blocks. The sample is then struck with a heavy hammer until the section of the weld between slots gets fractured.

The metal which is exposed need to be completely fused and free from slag inclusions. Gas pockets if any should never be more than 1.6mm across the higher dimension, The number of gas pockets should not exceed 6.

7.5.2 Fillet Weld Break Test

To judge the soundness of the fillet welds another break test method is employed which is called as Fillet Weld Break Test.

This test involves the breaking of a sample fillet weld that is single side welded. Therefore, the load is usually applied to the apex of the V-shaped specimen until the fillet weld breaks away. The failed sample is then examined for the soundness of the welding.

Fillet weld break tests provide a good indication of discontinuities within the entire length of the tested weld specimen, which was not possible in the macro etch test, which showed results only for a small cross-section. Though the fillet weld break test is often used on its own, it can also be used in conjunction with the macro etch test, as the two methods complement each other by providing information on similar characteristics but with different detail.

The fillet weld break test can detect discontinuities such as lack of fusion, internal porosity, and slag inclusions.

7.6 Toughness Test

The ability of materials to absorb energy before fracture is called toughness.

Toughness test provides a measure of resistance to crack initiation or propagation or both. The common methods of measuring the fracture toughness of welded joints are the Charpy V-notch impact test, the crack tip opening displacement (CTOD) test, drop weight test, and compact tension test. Of these testing methods, the Charpy V-notch (CVN) test is most used to determine fracture toughness (also known as "low-temperature notch toughness") of welds.

7.6.1 Charpy V-notch (CVN) Test

The equipment needed to conduct the test consists of a hammer located at the end of a pendulum. After the hammer is released from a set height, its force applies a consistent amount of energy to the weld specimen (held inside a special jig) and typically breaks this precision-machined notched specimen as it continues its fixed path. A computer calculates the CVN impact value by measuring the highest point the pendulum reaches after it contacts the weld.



Charpy V-notch Tester



Figure 74. Charpy V-notch

7.7 Transverse Tensile Test

Tensile strength refers to the ability of a metal to withstand the forces pulling it apart.

Transverse tensile test is performed to measure transverse tensile strength, yield strength, proof stress, elongation, and reduction of area of a butt joint under a static load. Because a large portion of design is based on tensile properties in the welded joint, it is important that the tensile properties of the base metal, the weld metal, the bond between the base and the weld, and the heat-affected zone conform to design requirements. Ultimate tensile strength, UTS (or just tensile strength for short) is an important property of materials to determine their mechanical performance.

Tensile strength is the maximum stress that a material can sustain in tension. In other words, we can say the amount of applied load per cross sectional area that a material can withstand before failure. Mathematically it is calculated as the ratio of maximum tensile load to the least cross section area (CSA) of the specimen.

$$\text{UTS} = \frac{\text{Maximum Load Applied}}{\text{Least CSA}}$$



Tensile Testing

Figure 75. Tensile Testing

The amount that the metal stretches is referred to as elongation.

The elongation and reduction of area measurements are used to determine the ductility of the metal. Ductility is the ability of metal to stretch and be permanently deformed without breaking or cracking.

A metal is said to be brittle if it has a poor elongation factor. Welding problems such as cracking and breaking are more common with brittle metals than with ductile metals.

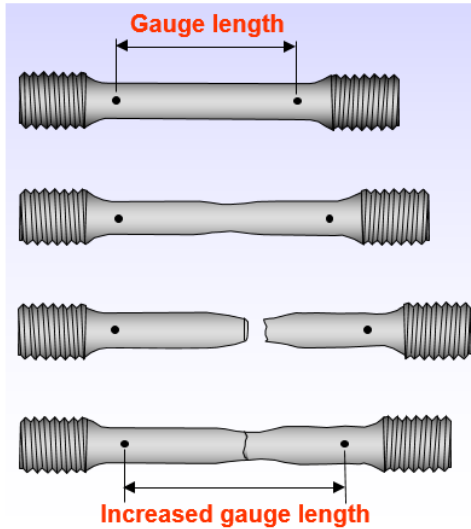

Figure 76. Gauge Length

A transverse tensile test piece from a weld joint will give the Stress/Strain characteristics of the joint.

Yield strength is the strength in tension that a material can withstand before it permanently deforms or stretches, and stays stretched. Yield strength is used while designing components or structures made of ductile materials.

Ultimate tensile strength (UTS) is defined as the maximum stress that a solid material can withstand before its failure. For ductile materials, ultimate strength is roughly 1.5 times higher than yield strength. Note that the UTS does not depend on the size of the sample. The same material with varying cross-sectional area will have the same value of tensile strength.

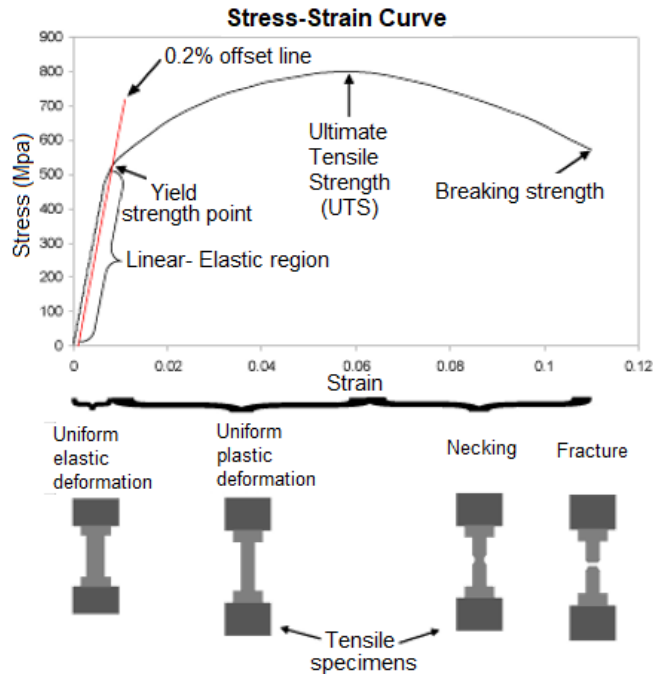

Figure 77. Ultimate tensile strength

This test is essential because a large proportion of design is based on the welded joint's tensile properties. The tensile properties of the base metal, the weld metal, the bond between the base and the weld, and the heat-affected zone must conform to the design requirements.

- a. If the weld metal strength is higher than the base metal, most of the plastic strain is transferred to the base metal, resulting in necking (a local reduction in cross-section area produced by stretching) and failure outside of the area. In this case, the test does not give an indication of the weld ductility.
- b. When the weld strength is significantly lower than the base metal, most of the plastic strain occurs in the weld.

Transverse weld specimens can be used to measure joint efficiency in terms of strength, but not for determining the ductility of the weld. Generally, a transverse tensile test is performed where the weld metal is oriented transverse in the center of the specimen.

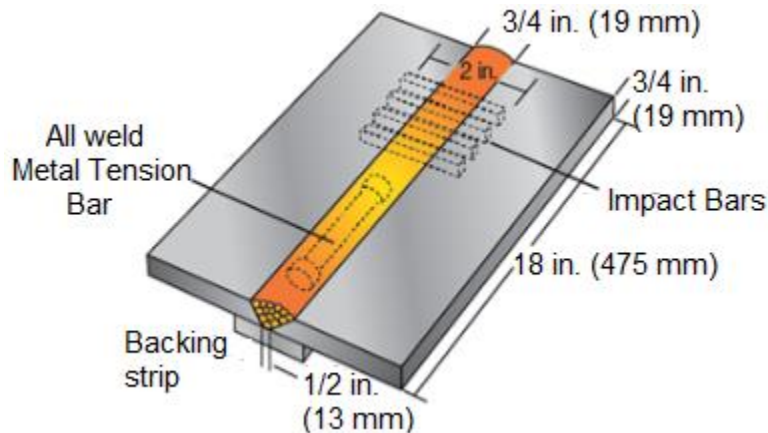

Figure 78. Weld Test Plate

Fillet welds' shear characteristics can be assessed using tension-shear testing.

Such tests are usually intended to represent completed joints in weldments and so are prepared using similar procedures.

The tension-shear test is the most popular method for determining the strength of resistance spot welds.

7.8 Bend Test

The bend test is used to determine the ductility and soundness of welded joints. The relative strengths of the weld metal, the HAZ, and the base metal are all important in the transverse bend test.

This method involves bending a weld specimen to a specified bend radius. The concept of a bend test is simple: two plates are welded together, and a flat strap of metal is cut from the welded plates. Next, the flat strap of a prescribed size is bent into a U-shape, stretching the material on the outer surface of the "U," while compressing the material on the inside surface. The purpose is to make certain the weld and the base metal are properly fused, and that the weld metal and the heat affected zone (HAZ) have appropriate mechanical properties.

There are three standard techniques for bend testing:

- a. Guided bend test: A bending test in which the specimen is bent to a definite shape by using a set of male and female dies.
- b. Roller bend test: A bending test in which the specimen is placed across the supports of rollers and is bent by the force of plunger.

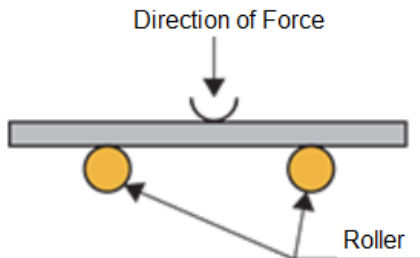

Figure 79. Roller Bend Test

- c. Free bend test: A bending test in which the lengthwise ends of a specimen are bent to an initial angle and then the specimen is bent freely by applying forces on both of the ends without using a set of male and female dies or a set of rollers.

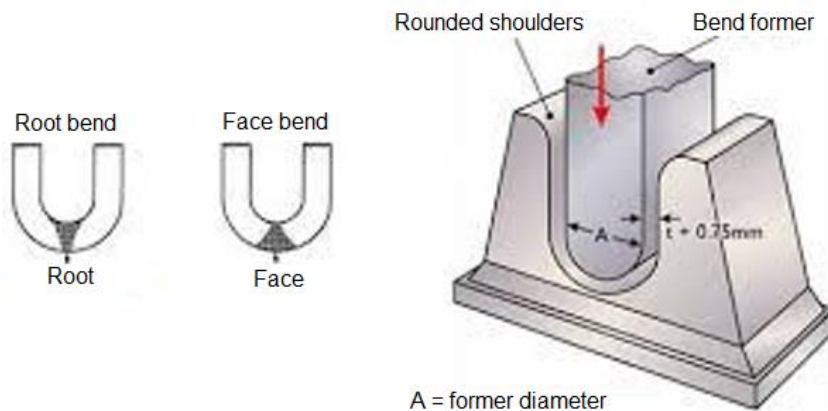

Figure 80. Free Bend Test

The guided bend test is most used in welding procedure and welder performance qualification tests. This type of testing is particularly good at finding liner fusion defects, which will often open in the plate surface during testing.

Face bend tests are made with the weld face in tension, while s are made with the weld root in tension. Side bend specimen is for testing the weld cross section. Bend specimens can be longitudinal or transverse to the weld axis, and they can be bent in three or four points (free bend) or around a mandrel with a specific diameter (guided bend).

7.9 Hardness Test

The ability of materials to resist penetration, abrasion, scratching or cutting is known as hardness. It is the property by which material resists permanent deformation.

Weld hardness testing is done on a cross-section of the joint region that has been ground, polished, or polished and etched. Indentations are made on the weld center line, the deposit's face, or root regions, the HAZ, and the base metal, among other places of interest.

Brinell, Rockwell, Vickers, and Knoop hardness tests can be used on welds to determine hardness, which is one of the simplest and easily evaluated mechanical property. The type of hardness test is determined by the material's hardness or strength, the size of the welded connection, and the type of information required.

- a. The Brinell test creates a big depression, typically 2 to 5.6 mm in diameter, which makes it ideal for large welds.
- b. The Rockwell test results in a much smaller indentation, which is more suited to hardness traverses.
- c. Vickers and Knoop tests leave relatively small indentations, making them ideal for hardness measurements in various HAZ areas and fine-scale traverses.

Carbon steels have a direct relationship between hardness and strength. As a result, if the hardness is known, the tensile strength can be estimated.

8 CHAPTER - 8 NON-DESTRUCTIVE TESTING (NDT)

NDT plays an important role in the quality control of a product. It is used during all the stages of manufacturing of a product and is used to monitor the quality of the:

- a. Raw materials which are used in the construction of the product.
- b. Fabrication processes which are used to manufacture the product.
- c. Finished product before it is put into service.

Use of NDT during all stages of manufacturing results in the following benefits:

- a. It increases the safety and reliability of the product during operation.
- b. It decreases the cost of the product by reducing scrap and conserving materials, labor and energy.
- c. It enhances the reputation of the manufacturer as producer of quality goods.
- d. It enables design of new products.

NDT is regulated by codes and standards according to the type of industry, country, and other criteria.

For the purposes of this course, we'll go through some NDT methods in greater depth, including the fundamental principles, typical applications, benefits, and drawbacks of various methodologies.

8.1 Types of Non-destructive Tests (NDT)

The six most common types of NDT are listed below; they differ in terms of the tools used and the methods employed to evaluate them, e.g. imaging techniques.

- a. Visual Testing (VT)
- b. Magnetic Particle Testing (MT)
- c. Penetrant Testing (PT)
- d. Ultrasonic Testing (UT)
- e. Radiographic Testing and Digital Radioscopy (RT/DR)
- f. Electromagnetic or Eddy current Testing (ET)

Other techniques include acoustic emission testing (AE), guided wave testing (GW), laser testing methods (LM), acoustic resonance testing (ART), leak testing (LT), magnetic flux

leakage (MFL), thermographic testing (TT), vibration analysis (VA) and infrared testing (IR).

All these methods apply physical concepts to the detection of faults or discontinuities in materials without impairing their functionality.

8.2 Visual Testing (VT)

Visual Testing (VT) is a non-destructive testing (NDT) method where a weld is examined with the eye to determine surface discontinuities. It ensures that procedures are followed and that mistakes are identified early on.

Visual inspection is carried out throughout the production cycle of a weldment. Broadly, visual inspection may be divided into three categories:

- a. Visual inspections before welding: drawings, material specifications, edge preparation, measurements, welding joint cleanliness, and so on.
- b. Visual examination during welding: welding process, electrode selection, operating conditions, preheat requirements, welder performance etc. are all examined visually during the welding process.
- c. Weld size (using weld gauges), defects (surface cracks, crater cracks, surface porosity, incomplete root penetration, undercut, underfill), warpage, base metal defects, and other visual inspections of the finished weldment.

Visual testing requires adequate illumination of the test surface and proper eyesight of the tester. To be most effective visual testing requires knowledge of product and process, anticipated service conditions, acceptance criteria, record keeping, among other training.

The applications of visual testing include:

- a. Checking of the surface condition of the component.
- b. Checking the weld distribution i.e. the weld material is evenly spread between the two linked metal parts.
- c. Checking of alignment of mating surfaces.
- d. Checking of shape of the component.
- e. Checking for evidence of leaking or seepage.
- f. Checking the weld is free of slag.

- g. Checking for internal side defects and porosity.

8.2.1 Equipment used for Visual Inspection

You can check with the naked eye as well as with tools like magnifying glasses or mirrors.

Some common type of equipment used for visual inspection includes:

- a. Rulers
- b. Tape measures
- c. Magnifiers
- d. Inspection glass
- e. Calipers
- f. Borescopes
- g. Remote crawlers with cameras etc. etc....

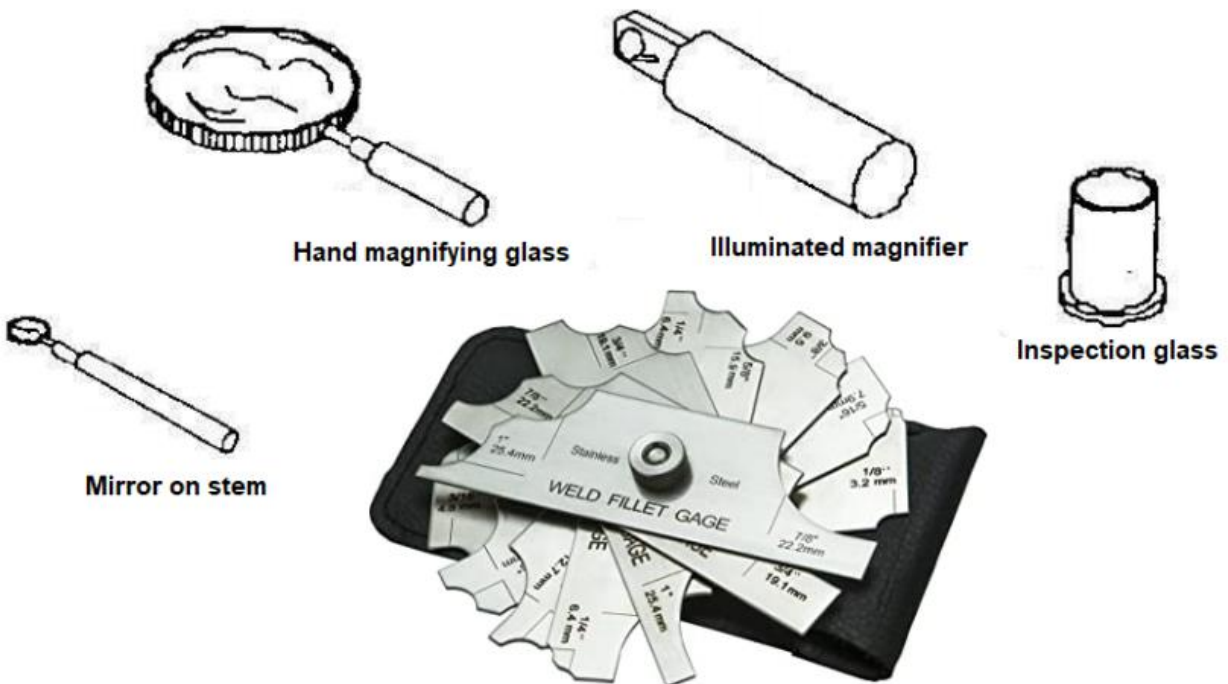

Figure 81. Visual Inspection Optical Aids

Weld handheld fillet gauge measures:

- a. The flatness of the weld

- b. Convexity (how the weld is welded outward)
- c. Concavity (how the weld is rounded inward)

8.2.2 Borescope Testing

One of the best examples of VT is Boroscopy. Borescope inspection has an eyepiece and an objective lens that are connected by an optical system that relays what the objective lens is seeing to the eyepiece. A light source is used to illuminate the area to be inspected.

Borescope testing is applied whenever there is a restriction or access limitations to examine the area of interest with naked eyes. It is commonly used to determine the occurrence of internal defects including corrosion, pitting or presence of foreign objects such as dust agglomerates, welding/grinding chips, cracks in the piping interior surface and the weld joints of the welded pipes, in-service pipes, pressure vessel, engine parts, or similar closed assemblies. The use of Boroscopy enhances the examination process, provides better understanding of the subject area and photographs of internal surface for condition monitoring or traceable record keeping.

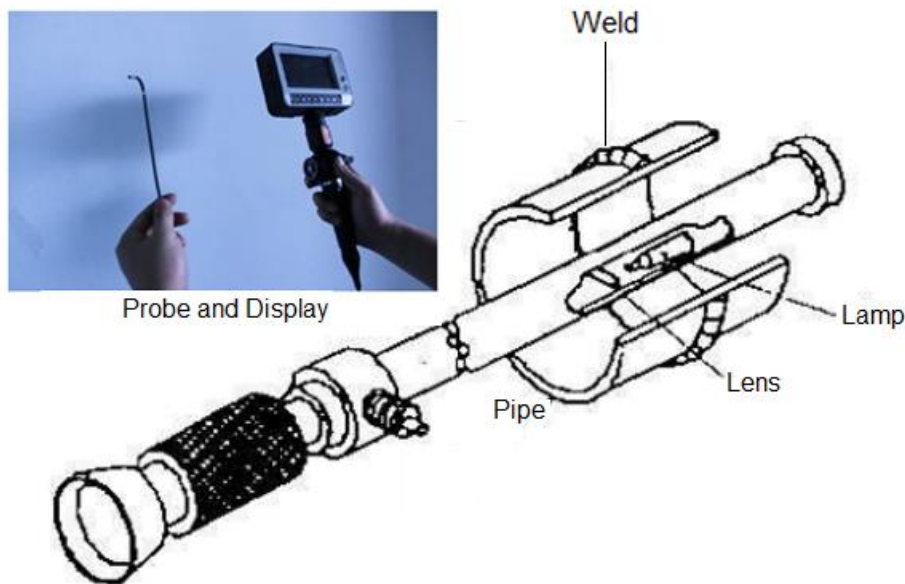

Figure 82.Borescope

8.2.3 Advantages and Disadvantages of VT

Advantages of nondestructive weld quality testing:

- a. Inexpensive (usually only labor expense)
- b. Low cost equipment
- c. No power requirement
- d. Quick identification of defects and downstream repair costs due to issues that weren't caught early

8.2.4 Disadvantages

- a. Inspector training necessary
- b. Good eyesight required or eyesight corrected to 20/40
- c. Can miss internal defects
- d. Report must be recorded by inspector
- e. Open to human error

If performed correctly, a visual inspection is the easiest and least-expensive technique. However, a good-looking weld doesn't always ensure internal quality, and discontinuities aren't always visible to the naked eye. So, it's important to conduct some form of nondestructive testing (NDT), also commonly referred to as nondestructive examination (NDE) for the critical components after these visual inspections are performed.

8.3 Liquid Penetrant Testing (PT)

Liquid penetrant testing is designed to locate minute leaks, cracks, pores, and discontinuity in the materials or weld surface. It is a choice of test for non-magnetic materials like magnesium, aluminum, and austenitic steel to locate any leak in every type of weld.

In this procedure, a liquid penetrant dye is sprayed onto the product surface for a predefined amount of time. The penetrant then 'creeps' into the tiniest cracks or pores by means of capillary action. There is no requirement of pressure. After the surface is dried, a developer is applied, which absorbs any remaining penetrant in the defect and displays all flaws, including their location, size, and the type.

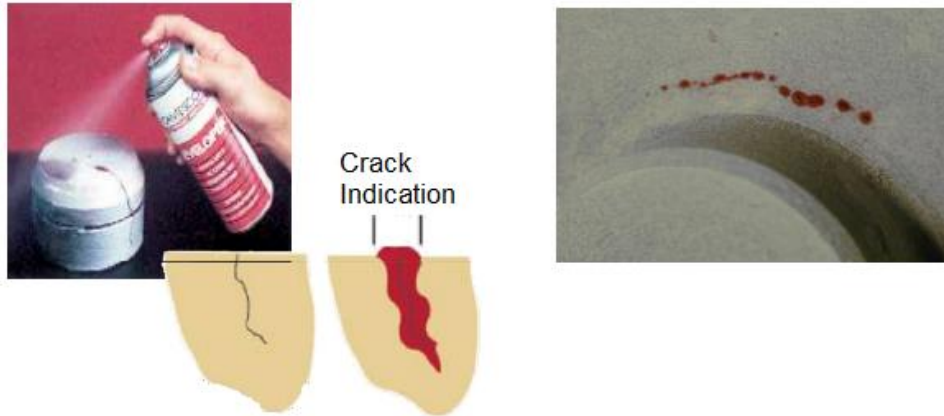

Figure 83. Liquid Penetrant Testing

When compared to unassisted visual inspection, this type of inspection is more likely to detect smaller and finer surface-breaking discontinuities, such as hairline cracks and micro surface porosity. It has an advantage over the magnetic particle method that it can be used for any material - both ferrous and nonferrous materials.

It however can't detect discontinuities that are sealed within the body of the weld, such as internal porosity or fusion defects. It's not usually suitable for testing rough or porous materials because interpretation of the test results can be hindered by false indications.

Liquid penetrant testing is done with either "visible dye" or fluorescent dye.

- a. For visible penetrant inspection, a bright red color dye and white developer are usually applied to the surface. The final inspection is made under regular light and used easily in the field.
- b. For a fluorescent inspection an ultra-violet fluorescent dye is used, which emits visible light under UV light or darkened conditions. A fluorescent penetrant is applied to one side of the joint, and a portable UV light is used to inspect the weld for leaks on the opposite side. It provides a greater contrast than the visible dye penetrants.

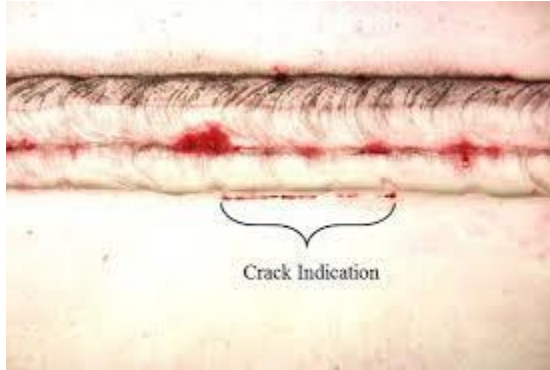

Figure 84. Liquid penetrant testing for a fluorescent inspection

8.3.1 Test Procedure

To perform a liquid penetrant test, follow these steps:

- a. Step 1. Pre-Cleaning: Clean the surface of the weld with the use of a solvent. Allow time for the area to dry completely.
- b. Step 2. Apply penetrant: After the application, the penetrant is normally left on the components surface for approximately 15-20 minutes (dwell time). The penetrant enters any defects that may be present by capillary action.
- c. Step 3. Clean off penetrant: After sufficient penetration time (dwell time), the dye should be removed by using a lint free cloth soaked in a solvent remover. Care must be taken not to wash any penetrant out off any defects present. After the penetrant has be cleaned sufficiently, a thin layer of developer is applied. The developer acts as a contrast against the penetrant and allows for reverse capillary action to take place.
- d. Step 4. Inspection / development time: Inspection should take place immediately after the developer has been applied. any defects present will show as a bleed out during development time. After full inspection has been carried out post cleaning is generally required.



Figure 85. Penetrant Testing Application

The process is purely a mechanical/chemical one and the various substances used may be applied in a large variety of ways, from aerosol spray cans at the simplest end to dipping in large tanks on an automatic basis at the other end. The latter system requires sophisticated tanks, spraying and drying equipment but the principle remains the same.

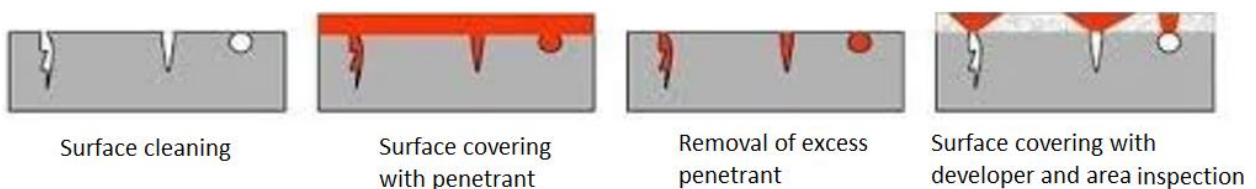

Figure 86. Illustration of Dye Penetrant Testing

8.3.2 Application

Liquid-penetrant examination is used to detect surface defects or leaks in all types of welds including pressure and storage vessels, as well as piping for the petroleum industry. This test can be used on aluminum, magnesium, and stainless-steel weldments where the magnetic particle examination method cannot be used.

This method is widely used for testing of both magnetic and non-magnetic materials.

8.3.3 Advantages

The advantages of liquid penetrant testing are as follows:

- a. Economical with a low cost
- b. Easy process and its interpretation
- c. Highly sensitive to fine, tight discontinuities.
- d. Not much training required
- e. Used for ferrous and nonferrous metals. Best method for surface breaking cracks in non-ferrous metals.

8.3.4 Limitations

The limitations of liquid penetrant testing are as follows:

- a. Detects surface discontinuities only. May skip the problem under the surface.
- b. Does not work on a porous and very rough or brittle surfaces.
- c. Removal of all penetrant materials, following the test, is often required.
- d. Uses a considerable quantity of consumables.
- e. There is no easy method to produce permanent record.

8.4 Magnetic Particle Testing (MT)

Magnetic particle testing (MT) is a rapid non-destructive physical weld test to locate the defect at or near the surface of the steel metal and magnetic alloys by employing means of correct magnetization with ferromagnetic particles application.

The method is based upon two principles:

- a. A magnetic field is produced when an electric current has flowed through a metal.
- b. The minute poles are formed on the surface where the magnetic fields are broken or distorted.

When this ferromagnetic stuff is brought in the vicinity of the magnetized part, they by nature attract strongly towards these poles and hold there firmly and form a visible indication. It's important to note that magnets will attract materials only where the lines of force enter and leave the magnet at the poles. If a magnet is bent and the two poles are

joined to form a closed loop, no external poles will exist, and consequently, it will have no attraction to magnetic material. This is the basic principle of magnetic particle testing. If the part has no cracks or other discontinuities, magnetic particles will not be attracted, and you'll know your weld is without surface cracks.

8.4.1 Testing Method

This testing method consists of establishing a magnetic field in the part to be tested either using a permanent or electromagnet, or by sending electric current through the test specimen. When minute magnetic particles (e.g. iron fillings) in the size range 20 to 30 microns are applied on the surface with a liquid or powder, they are attracted by the magnetic ends or poles. Inconsistencies are then revealed by change in the magnetic field, which causes the particles to be aligned differently from the 'good' part of the object. In this way cracks or inclusions of non-magnetic materials can be quickly detected. Especially remarkable is the detection of small cracks with a width of 0.001 mm and a depth of 0.01 mm. For comparison: a human hair has a thickness of 0.04 mm or more.



Figure 87. Magnetic Particle Testing of a Pipeline

The piece can be magnetized by direct or indirect magnetization.

- a. Direct magnetization occurs when the electric current is passed through the test specimen and a magnetic field produced by this flow of current is used for the detection of defects.

- b. Indirect magnetization occurs when no electric current is passed through the test object, but a magnetic field is induced into the specimen either using a permanent magnet or by flowing current through a coil or a conductor.

The electricity used to generate the magnetic flux in any of these methods can be alternating current (AC) or direct current (DC).

- a. Alternating Current (AC). Electric current flows through a conductor in a back and forth direction at specific intervals. Note: AC generated magnetic flux follows the contours of the surface and does not penetrate deeply into the material. It provides the best sensitivity for the detection of surface discontinuities only.
- b. Direct Current (DC). Electric current flows through a conductor in only one direction. Note: DC from a battery source has been phased out in favor of rectified forms of AC for surface and subsurface flaw detection:
 - Full-Wave Rectified (FWDC). Electric current flows through a conductor in one direction only with an increased rate of pulsating surges and drops at specific intervals. Note: FWDC is recommended for effective surface and subsurface flaw detection when using the wet method of inspection.
 - Half-Wave Rectified (HWDC). Electric current flows through a conductor in one direction only with pulsating surges and drops at specific intervals-hence the name half wave. Note: HWDC penetrates more deeply but is less likely to follow rapid sectional changes. HWDC is effective for detecting flaws that are slightly below the surface.

The pulsating effect of AC and HWDC gives the indicating particles more mobility. DC penetrates far deeper, yet it lacks this capability. Furthermore, demagnetizing the material after DC magnetizing is significantly more difficult than demagnetizing the material after AC magnetizing.

8.4.2 Equipment Details

8.4.2.1 Yokes

Most field inspections are performed using a Yoke, as shown below. When the legs are placed on a ferromagnetic part and the yoke is energized, a magnetic field is introduced

into the part. Because the flux lines do run from one leg to the other, discontinuities oriented perpendicular to a line drawn between the legs can be found. To ensure no indications are missed, the yoke is used once in the position shown then used again with the yoke turned 90° so no indications are missed. Because all the electric current is contained in the yoke and only the magnetic field penetrates the part, this type of application is known as indirect induction.

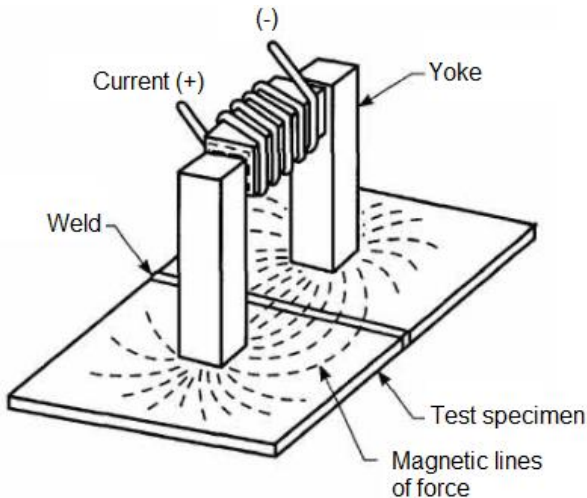

Figure 88. Indirect Induction

8.4.3 Prods

A second technique involves using clamps or prods, which are attached or placed in contact with the component. Electrical current flows through the component from contact to contact. The current sets up a circular magnetic field around the path of the current.

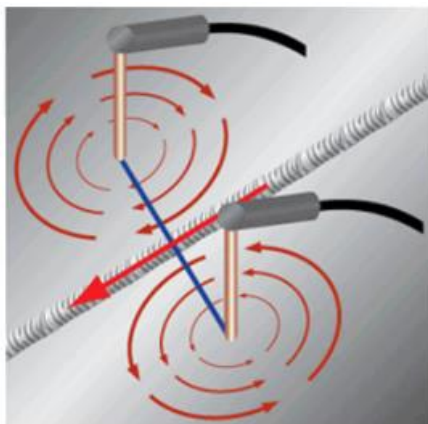

Figure 89. Illustration of Magnetic Particle Testing

Prods induce a circular magnetic field by sending a high amperage (1000A typically) current through the test piece. The use of prods is sometimes restricted because there is a potential for arcing that could damage parts.

8.4.3.1 Coils

Electric coils are used to generate a longitudinal magnetic field. When energized, the current creates a magnetic field around the wires making up the coil so that the resulting flux lines are oriented through the coil as shown at the right. Because of the longitudinal field, indications in parts placed in a coil are oriented transverse to the longitudinal field.

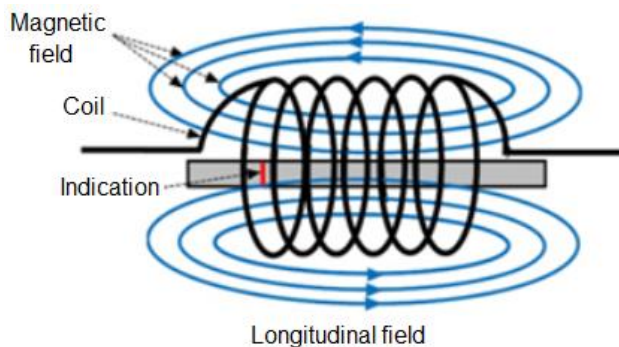

Figure 90. Electrical Coils

8.4.4 Advantages

Advantages of magnetic particle testing include the following:

- a. Simplicity of operation and application.
- b. It does not need very stringent pre-cleaning operation.
- c. Best method for the detection of fine, shallow surface cracks in ferromagnetic material.
- d. Will work through thin coating.
- e. Inspection of complex geometries.
- f. Portable NDT method.
- g. Can be automated, apart from viewing. (Though modern developments in automatic defect recognition can be used in parts of simple geometry e.g. billets and bars. In this case a special camera captures the defect indication image and processes it for further display and action).

8.4.5 Limitations

The limitations of magnetic particle testing include the following:

- a. This test can be used only in ferromagnetic materials such as iron, nickel, cobalt, and some other alloys. Cannot inspect non-ferrous materials such as aluminum, magnesium, or most stainless steels
- b. Restricted to surface or near surface flaws.
- c. Orientation and strength of magnetic field is critical. There is a need to magnetize twice: longitudinally and circumferentially.
- d. Not fail safe in that lack of indication could mean no defects or process not carried out properly.
- e. Large currents sometimes required and —burning of test parts is a possibility.
- f. Ferromagnetic parts that have been magnetized during testing may retain a certain amount of residual magnetism. The testing object must be demagnetized after testing, which may be cumbersome.

8.5 Radiographic Testing and Digital Radiography (RT/DR)

Radiographic testing (RT) refers to an imaging test method that allows a view into the inside of a component.

Digital Radiography (DR) using X-ray image intensifiers or radioscopy systems is becoming increasingly popular because images can be stored and evaluated digitally.

Radiography uses X-rays - these rays penetrate through the weld and makes a shadow picture on a film which is placed behind the material. These rays have a very short wavelength of the order of 0.001 Angstrom. And often gamma rays produced by a radioactive material (Co-60 & Ir-192 radioisotopes) are also used for the inspection of welds in field settings.

8.5.1 The Principles of Radiography

The basic principle of radiographic inspection of material objects is the same as the medical radiography. The test object is placed between the radiation source and a radiographic film. Some radiation is absorbed by the test object before reaching the exposed film.

The ability of rays to penetrate through the metal mainly depends on the density of metal and they can penetrate more easily where less density of metal is present, and it leads to the formation of shadow picture on the film. And any defects in the casting can easily be identified from the shadow picture.

- a. Thinner areas or the materials of a less density or the areas exposed to more energy show as darker areas on the radiograph. These darkened areas are the cavities, defects, or voids because more radiation has managed to reach the film.
- b. Thicker areas, or the materials of a greater density or the areas exposed to lower energy show as lighter areas on a radiograph.

The voltage delivered to the X-Ray tube determines the penetrating power in X-radiography; in steel, approximately 1000 volts per inch thickness is required. In X-radiography the intensity, and the exposure time, is governed by the amperage of the cathode in the tube.

8.5.2 Gamma Radiography

In Gamma radiography the isotope governs the penetrating power and is unalterable in each isotope. Thus, for 1/2" to 1" steel, Iridium 192 is used, and for 3/4" to 2 1/2" steel, Caesium 134 is normally used. With Gamma rays the intensity of the radiation is set at the time of supply of the isotope.

This radiographic physical weld testing and inspection method is similar to an X-ray method except that these gamma rays emerge from a capsule of radium sulfate instead of a tube in the X-ray.

The feature of the short wavelength of gamma rays finds it perfect for penetrations of larger thickness sections. The time required for exposure is longer than the X-ray because of a slower rate of gamma ray's production.

X-ray testing is most often used in radiographic inspections, but portability is the unique feature of the gamma rays.

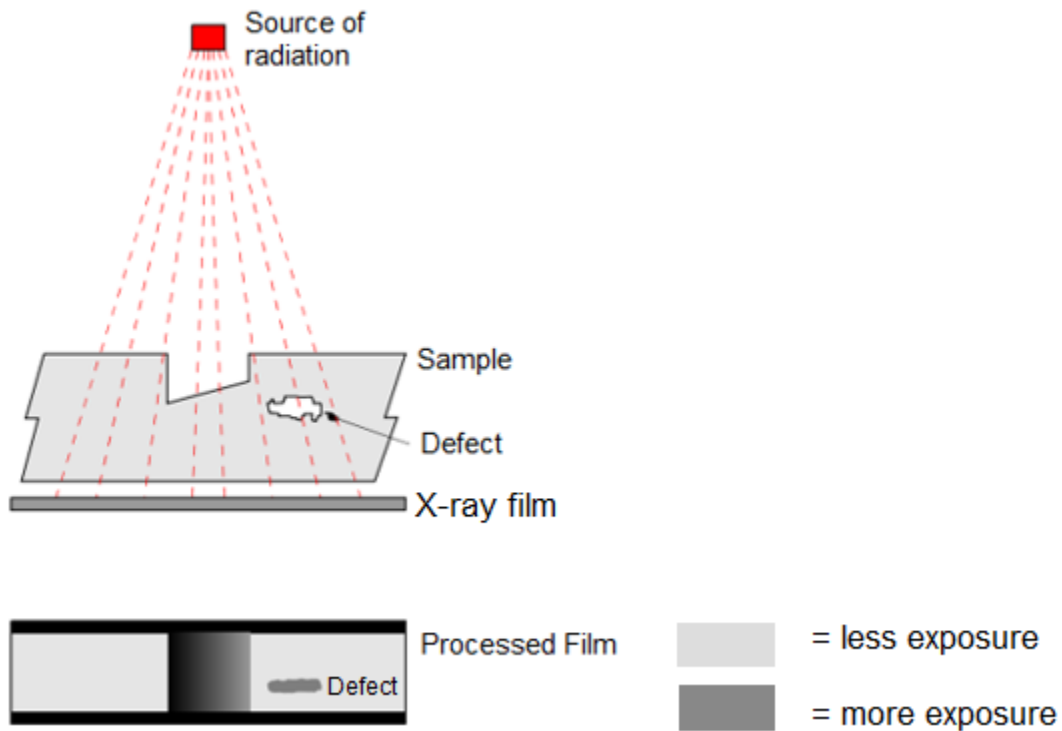

Figure 91. Radiography

Various radiographic and photographic accessories are necessary, including such items as radiation monitors, film makers, image quality indicators, darkroom equipment, etc. Also required are such consumable items as radiographic film and processing chemicals.

8.5.3 Applications

The radiographic testing method is suitable for the detection of internal flaws in many different materials and configurations including ferrous and nonferrous metals. This method is used on wide variety of products such as forgings, castings, and weldments.

8.5.4 Advantages

The advantages of radiographic testing include:

- a. It is used for examination of weldments in all types of materials.
- b. Detects both surface and subsurface defects
- c. It provides permanent record.
- d. Devices for checking the quality of radiograph are available.

- e. Technique is not limited by material type or density

8.5.5 Limitations

Some of the limitations of this method are:

- a. Harmful radiation - can have serious health and safety implications.
- b. Bulky equipment.
- c. Not suitable for surface defects.
- f. Access to both sides of the object is required.
- g. Orientation of equipment and flaw can be critical
- h. Defect require significant depth in relation to the radiation beam (not good for planar defects)
- d. No indication of depth of a defect below the surface
- e. The thickness range that can be inspected is limited.
- f. Sensitivity of inspection decreases with thickness of the test object.
- g. Considerable skill is required for interpretation of the radiographs.
- h. The depth of defect is not indicated readily.
- i. Slow results.

8.6 Ultrasonic Testing (UT)

Ultrasonic testing (UT) allows a view into the inside of a component.

Ultrasonic inspection is used to detect defects like cracks and porosity within the interior of the casting or material. This method uses reflection and transmission of high frequency sound waves, which are much higher than the audible range and then these waves are made pass through the weld piece for inspection. The presence and location of discontinuities is determined by detecting and analyzing the reflected beam.

The system uses a transducer, which converts electrical energy to mechanical energy. The transducer is excited by a high-frequency voltage that causes a crystal to vibrate mechanically. The crystal probe is moved over the surface of a component and the ultrasonic waves emitted by it or their reflections are tracked on a screen of a cathode ray oscilloscope. When the pulse of ultrasonic waves strikes a discontinuity in the test piece,

it is reflected to its point of origin. The transducer serves as a receiver for the reflected energy.

A phased-array imaging test can also be performed, which allows easier interpretation. Both flat and voluminous imperfections can be inspected. In the case of surface imperfections, it is often superior to radiographic testing (RT). It is used, for example, for wall thickness measurement with vertical probes and for simple geometries with angle probes.

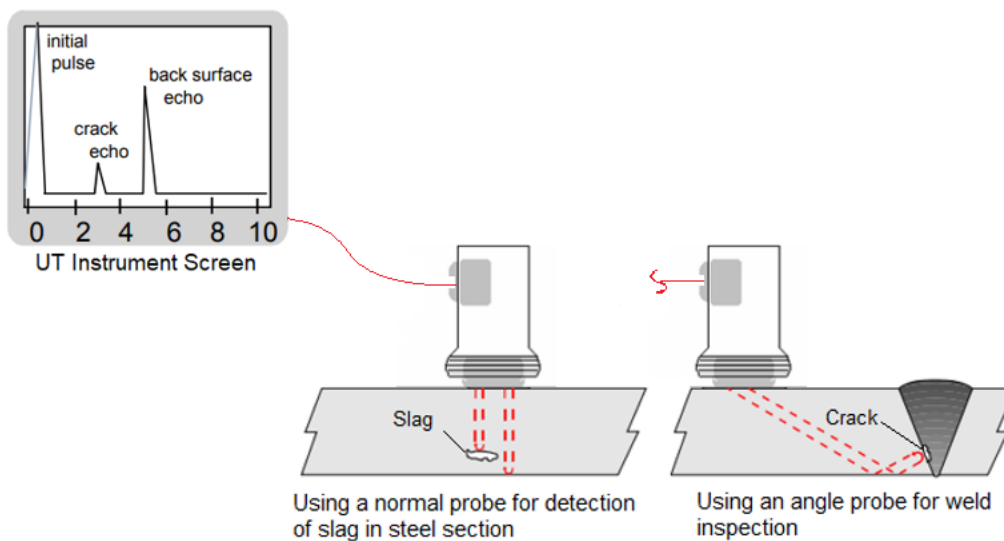

Figure 92. Ultrasonic Flaw Detection

One of the most useful characteristics of ultrasonic testing is its ability to determine the exact position of a discontinuity in a weld. This testing method requires a high level of operator training and competence and is dependent on the establishment and application of suitable testing procedures. An experienced inspector will notice any abnormalities in wave frequency – by hearing reflected sound. When no echo is heard -- it may be grounds for rejecting the weld.

8.6.1 Equipment

Pulse rate generator (piezoelectric crystal), transducer, amplifier, timer, and cathode ray oscilloscope (all are portable). Modern ultrasonic flaw detectors are fully solid state and can be battery powered and are robustly built to withstand site conditions.

8.6.2 Applications

This testing method can be used to find internal flaws on ferrous and nonferrous materials. This technique can also be applied to determine the material thickness and the mechanical properties and grain structure of materials.



Figure 93. Ultrasonic Testing of a Pipeline

8.6.3 Advantages

Some of the advantages of ultrasonic testing are:

- a. It has high sensitivity even to minute defects and allows for the precise determination of the location and size of the flaws.
- b. It has more penetrating capability than radiography and can find faults in the test object at a deeper level (up to about 7 meters of steel).
- c. It has a high accuracy of measurement of flaw position and size.
- d. It has fast response which permits rapid and automatic inspection.
- e. It needs access to only one surface of the specimen.

8.6.4 Limitations

Some of the limitations of this method are:

- a. Requires high operator skill
- b. Good surface finish is necessary
- c. Defect identification

- d. Couplant may contaminate
- e. No permanent record
- f. Calibration required
- g. Ferritic Material (Mostly)
- h. Unfavorable geometry of the test object causes problems during inspection.
- i. Inspection of materials having coarse grain microstructure is difficult.

8.7 Electromagnetic or Eddy current testing (ET)

Magnetic particle testing for surface defects of ferrous metals. This method can be used effectively with both ferromagnetic and non-ferromagnetic materials.

Eddy Current Testing (ET) uses the principle of “electromagnetism” as the basis for conducting examinations. By bringing the object close to an alternating current carrying coil, eddy currents are induced in the object. The magnetic field of the coil is modified by the magnetic fields in the object. These changes the impedance, which is displayed in a meter reading or a cathode ray oscilloscope. When a crack appears in the product surface, eddy currents must travel further around the break, causing a change in impedance.

The magnitude of the eddy currents generated in the product is dependent on conductivity, hardness, permeability, and the set-up geometry. The simplest coil comprises a ferrite rod with several turns of wire wound at one end and which is positioned close to the surface of the product to be tested (refer figure below).

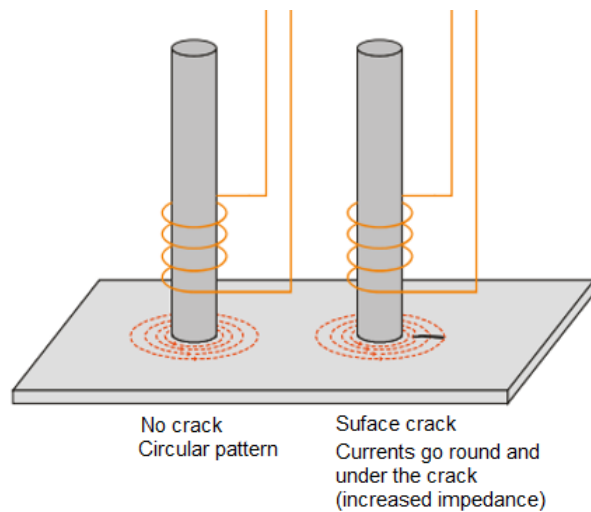

Figure 94. Coil with Single Winding

Where surfaces are to be scanned automatically, the single coil windings are suitable only if the lift off distance is precisely maintained. With higher speed scanning systems, differential coil configurations are generally used to cancel out lift off effects, vibration effects, and other undesirable effects.

There are three types of probes used in eddy current testing.

- a. Internal probes are commonly used for the in-service testing of heat exchanger tubes.
- b. Encircling probes are commonly used for the testing of rods and tubes during manufacturing.
- c. Surface probes are used for locating cracks in plates, sifting materials, measuring wall and coating thickness, and case depth measurement.

As the probe is scanned across the surface of the component, the cracks can be detected. The depth to which the eddy currents penetrate a material can be changed by adjusting the test frequency – the higher the frequency, the lower the penetration; however, the lower the frequency, the lower sensitivity to small defects.

Larger coils are less sensitive to surface roughness and vice versa. The latest electronic units can operate a wide range of coil configurations in absolute or differential modes and at a wide range of frequencies.

Most eddy current electronics have a phase display, and this gives an operator the ability to identify defect conditions. In many cases signals from cracks, lift off and other parameters can be clearly identified. Units are also available which can inspect a product simultaneously at two or more different test frequencies.

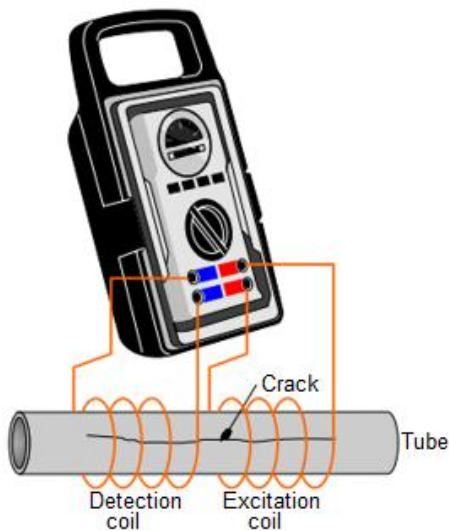

Figure 95. Eddy Current Testing Equipment

8.7.1 Applications

The eddy current test is purely electrical. The coil units do not need to contact the product surface and thus the technique can be easily automated. Most automated systems are for components of simple geometry where mechanical handling is simplified.

ET method may be used for:

- a. For the detection of defects in tubing's.
- b. For sorting materials.
- c. For measurement of thin wall thicknesses from one surface only.
- d. For measuring thin coatings.
- e. For measuring case depth.

Only electrically conductive materials are suitable for this procedure.

8.7.2 Advantages

The advantages of eddy current testing include:

- a. Gives instantaneous response.
- b. Is extremely compact and sensitive to surface cracks.
- c. Does not use consumables (except probes – which can sometimes be repaired).
- d. Allows use of high scanning speeds (as high as 10 m/s).
- e. Flexible in selection of probes and test frequencies to suit different applications.
- f. Accurate for sizing defects and coating thickness measurement.
- g. These tests can not only detect discontinuity in test metal pieces but can measure the dimensions and resistivity.

8.7.3 Limitations

Eddy current inspection is generally restricted to the depth less than 6mm, that's why it is not as sensitive to small open defects of high depth as liquid penetrant testing or magnetic particle inspection. But it can replace penetrant testing method for detection of surface connected discontinuities.

The limitations of eddy current testing include the following:

- a. Extremely sensitive to surface variations and therefore requires a good surface.
- b. It is applicable to electrically conducting materials only.
- c. Not reliable on carbon steel for the detection of subsurface flaws.
- d. Its depth of penetration is limited to 6 mm.

8.8 Comparison of different NDT methods

We learned that the six most frequently used NDT methods are: visual testing (VT), radiographic testing (RT), ultrasonic testing (UT), magnetic particle testing (MT), liquid penetrant testing (PT) and electromagnetic testing (ET).

Table below provides a summary of the most frequently used NDT methods. The costs are represented in scale of 1 to 5 with 1 being the lowest and 5 being the highest.

Technique	Access requirements	Costs		Remarks
		Equipment	Inspection	
Visual methods	Can be used to view the interior of complex equipment. One point of access may be enough.	1	1	Very versatile; Little skill required; Repays consideration at design stage.
Radiography	Must be able to reach both sides.	5	4	Despite high cost, large area can be inspected at one time. Considerable skill required in interpretation.
Ultrasonics	One or both sides (or ends) must be accessible.	4	3	Requires point-by-point search hence extensive work needed on large structures; Skilled personnel required.
Magnetic particle	Requires a clean and reasonably smooth surface.	3	2	Only useful on magnetic materials such as steel; Little skill required; Only detects surface breaking or near surface cracks.
Penetrant flaw detection	Requires flaw to be accessible to	1	2	For all materials Some skill required;

Technique	Access requirements	Costs		Remarks
		Equipment	Inspection	
	the penetrant (i.e. clean and at the surface).			Only detects surface breaking defects; Rather messy.
Electromagnetic	Surface must (usually) be reasonably smooth and clean	4	2	For electrically conductive materials only; For surface breaking flaws; Variations in thickness of coatings, or comparison of materials; For other than simple comparison considerable skill is usually required.

Table 3. Summary of the most frequently used NDT methods

8.9 Applications of NDT

Now that we understand the advantages and limitations of various NDT methods, the most efficient and effective method is dependent on the application, the type of flaw, material properties, costs, desired accuracy levels, setup of equipment etc.

The Table below provides some common applications of the NDT. The following abbreviations are used:

- a. RT: X or Gamma Radiography
- b. MT: Magnetic Particle Inspection
- c. PT: Dye Penetrant
- d. UT: Ultrasonic
- e. ET: Eddy Current

Material	FLAWS						
	Surface Cracks	Sub-Surface Cracks	Internal Flaws	Lack of Fusion	Slag, Porosity	Material Quality	Thickness
Ferrous Forgings & Stampings	MT	MT, UT	RT, UT		RT, UT		UT
Ferrous Raw Materials & Rolled Products	MT	MT, UT	UT		MT, UT		UT
Ferrous Tube & Pipe	MT	MT, ET	UT	UT	MT, UT		UT
Ferrous Welds	MT, UT	UT	RT, UT	RT, UT	RT, UT		UT
Steel Castings	MT	MT, UT	RT, UT		RT, UT		UT
Iron Castings	MT	UT, ET	UT		RT, UT	UT	UT
Non-Ferrous Components & Materials	PT, ET		RT, UT	UT	PT, UT		UT
Ferrous Components Finished	MT	UT, ET	RT, UT	UT	MT, UT		UT

Material	FLAWS						
	Surface Cracks	Sub-Surface Cracks	Internal Flaws	Lack of Fusion	Slag, Porosity	Material Quality	Thickness
Non-Ferrous Components Finished	PT, ET	UT, ET	RT, UT		UT, ET		UT
Aircraft Ferrous Components	RT, MT, ET	MT, UT	RT, UT	UT	MT, UT		UT
Aircraft Non-Ferrous Components	RT, PT, ET	RT, UT	RT, UT	UT	PT, UT		UT

Table 4. Common Applications of the NDT

8.9.1 Comparison based on Test Application

Defect form is usually divided into two categories: volumetric, in which the height-to-width ratio is close to unity, and Planar, in which the width is relatively narrow in comparison to the height.

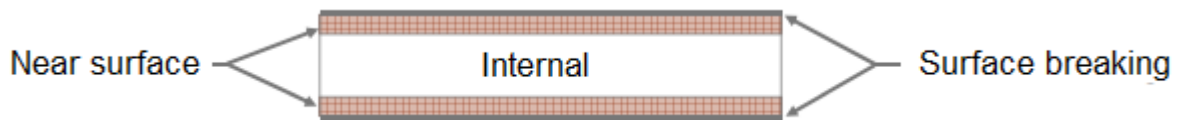

Figure 96. Defect Form

	Volumetric flaws	Planar flaws
Surface breaking	Visual, liquid penetrant	Visual

Near surface	Magnetic particle and eddy current	Magnetic particle and eddy current
Internal	Ultrasonic testing and radiography	Ultrasonic testing

Table 5. Volumetric flaws VS Planar flaws

9 CHAPTER – 9 ACCEPTANCE CRITERIA FOR WELD DEFECTS

This chapter covers the weld defect acceptance criteria as per ASME Section VIII Div. 1, which is one of the most widely used standards for acceptance criteria for weld defects.

- a. Acceptance criteria for Visual Inspection
- b. Acceptance criteria for Radiography Test (RT)
- c. Acceptance criteria for Ultrasonic Test (UT)
- d. Acceptance criteria for Liquid Penetrant Test (LPT/LPI/DPT)
- e. Acceptance criteria for Magnetic Particle Test (MPI/MPT/MT)

9.1 Acceptance criteria for Visual Inspection

(Refer: UIG-97, Page – 345 of ASME BPVC Section VIII Div. 1, 2017 Edition.)

- a. The surface shall be free of any visible laminations, spalling, or cracks. Cracks in tubes shall not be repaired and shall be considered cause for rejection.
- b. For tubes, the depth of scratch shall not exceed 1/32 in. (0.8 mm). For all other material, the scratch depth shall not exceed 1/8 in. (3 mm).

For an acceptable limit of thickness reduction, Refer to UW-35 (sub-para b, page – 144) which states that:

The reduction in thickness shall not exceed 1mm (1/32 in.) or 10% of material nominal thickness whichever is less, provided that the material of the adjoining surfaces below the design thickness at any point.

For the allowable limit of Weld Reinforcement (excess weld metal), Refer to UW-35 (sub-para d, Page – 144)

S.N.	Nominal Thickness of material (In mm)	Maximum allowable reinforcement (in mm)	
		Categories B and C Butt welds	Other welds
1	Less than 2.4	2.5	0.8
2	2.4 to 4.8, inclusive	3	1.5
3	Over 4.8 to 13, inclusive	4	2.5
4	Over 13 to 25, inclusive	5	2.5
5	Over 25 to 51, inclusive	6	3
6	Over 51 to 76, inclusive	6	4
7	Over 76 to 102, inclusive	6	5.5
8	Over 102 to 127, inclusive	6	6
9	Over 127	8	8

Table 6. Nominal Thickness and maximum allowable reinforcement of a material

9.2 Acceptance criteria for Radiography Test (RT)

(Refer: UW-51: Sub Para b (Page 148 and 149) and Mandatory Appendix 4 (Page 400 and Page 403) of ASME BPVC Section VIII Div. 1, 2017 Edition.)

Following terminologies have been used to explain the acceptance/rejection criteria for Radiography Test (RT).

- a. **Linear Indication:** Any indication with a length greater than three times the width. Linear indications are mainly cracks, lack of penetration, lack of fusion, and elongated slag inclusions.
- b. **Rounded Indication:** Any indication with a length equal to or less than three times the width. A rounded indication may be circular, elliptical, conical, or irregular in shape and may have tails too. While determining the size of an indication, the tail shall also be included. Rounded indications may appear on radiographs from any imperfection in the weld, such as porosity, slag, or tungsten.

9.2.1 Acceptance criteria for Linear Indication (UW – 51)

- a. Any crack, lack of penetration, and lack of fusion shall not be accepted.

- b. Any other elongated indication shall be considered unacceptable, which has a length greater than:
- 6 mm (1/4 in.) for T up to 19 mm (3/4 in.)
 - T/3 for T greater than or equal to 19 mm (3/4 in.) and less than or equal to 57 mm (2-1/4 in.) i.e. $19 \text{ mm} \leq T \leq 57 \text{ mm}$.
 - 19 mm (3/4 in.) for T greater than 57 mm (2-1/4 in.)
- (Where, 'T' – Thickness of the weld metal excluding any allowable reinforcement).
- c. Any group of indications (inline) with an aggregate length of more than T (within a length of 12T) shall be considered unacceptable except when the distance between the successive discontinuities exceeds 6L. (where 'L' is the length of the longest imperfection in the group).

9.2.2 Acceptance criteria for Rounded Indication (Mandatory Appendix 4)

According to this appendix, those rounded indications which exceed the following dimensions shall be considered relevant.

- a. T/10 for T less than 3 mm (1/8 in.)
- b. 0.5 mm (1/64 in.) for T from 3 mm to 6 mm (1/8 in. to 1/4 in.), inclusive
- c. mm (1/32 in.) for t greater than 6 mm to 50 mm (1/4 in. to 2 in.), inclusive
- d. 1.5 mm (1/16 in.) for T greater than 50 mm (2 in.)

Apart from the above conditions, Mandatory Appendix 4 also contains some tables, charts, and figures as a reference for acceptance/rejection criteria.

9.3 Acceptance criteria for Ultrasonic Test (UT)

(Refer: Mandatory Appendix 12 (Page 435) of ASME BPVC Section VIII Div. 1, 2017 Edition.)

- a. Indications characterized as cracks, lack of fusion, or incomplete penetration are unacceptable regardless of length.
- b. Other imperfections are unacceptable if the indications exceed the reference level amplitude and have lengths that exceed:

- 6 mm (1/4 in.) for T up to 19 mm (3/4 in.)
- T/3 for T from 19 mm to 57 mm (3/4 in. to 21/4 in.)
- 19 mm (3/4 in.) for T over 57 mm (21/4 in.)

where T is the thickness of the weld excluding any allowable reinforcement. For a butt weld joining two members having different thicknesses at the weld, T is the thinner of these two thicknesses. If a full penetration weld includes a fillet weld, the thickness of the throat of the fillet shall be included in T.

9.4 Acceptance criteria for Liquid Penetrant Test

(Refer: Mandatory Appendix 8 (Page 417) of ASME BPVC Section VIII Div. 1, 2017 Edition.)

The following terminologies have been used to explain the acceptance/rejection criteria for Liquid Penetrant Examination (PT).

- a. Relevant Indications: Indications with major dimensions greater than 1.5 mm (1/16 in.) shall be considered relevant.
- b. Linear Indication: Any indication with a length greater than three times the width.
- c. Rounded Indication: Any indication with a length equal to or less than three times the width. A rounded indication may be of circular or elliptical shape.

9.4.1 Acceptance Criteria for Liquid Penetrant Examination (Mandatory Appendix 8)

All surfaces to be examined shall be free of:

- a. Relevant linear indications shall be rejected.
- b. Relevant rounded indications greater than 5 mm (3/16 in.) shall be rejected.
- c. Four or more relevant rounded indications in a line separated by 1.5 mm (1/16 in.) or less (edge to edge).

9.5 Acceptance criteria for Magnetic Particle Test (MT)

(Refer Mandatory Appendix 6 (Page 412) of ASME BPVC Section VIII Div. 1, 2017 Edition. Acceptance criteria are the same as that of Liquid Penetrant Examination)

The following terminologies have been used to explain the acceptance/rejection criteria for Magnetic Particle Test (PT).

- a. Relevant Indications: Indications with major dimensions greater than 1.5 mm (1/16 in.) shall be considered relevant.
- b. Linear Indication: Any indication with a length greater than three times the width.
- c. Rounded Indication: Any indication with a length equal to or less than three times the width. A rounded indication may be of circular or elliptical shape.

9.5.1 Acceptance Criteria for Magnetic Particle Examination (Mandatory Appendix 6)

All surfaces to be examined shall be free of:

- a. Relevant linear indications shall be rejected.
- b. Relevant rounded indications greater than 5 mm (3/16 in.) shall be rejected.
- c. Four or more relevant rounded indications in a line separated by 1.5 mm (1/16 in.) or less (edge to edge).

Summary

NDT is increasingly being used in process control to meet the need for a good quality assurance concept of making the products right the first time. Visual and penetrant testing are the NDT methods detect surface discontinuities. Radiographic and ultrasonic weld inspection are used to detect discontinuities within the internal structure of welds. The obvious advantage of both these methods is their ability to help establish the weld's internal integrity without destroying the welded component.

NDT equipment has become more dependable and sensitive as a result of a movement toward making it as error-free as feasible.

NDT equipment has become more reliable and sensitive with a trend to make it as independent of operator errors as possible. There has been a greater usage of computers and automation. The majority of modern NDT uses microprocessors and computers with increased image processing, data collecting, and analysis capabilities.

There is a growing trend towards using multiple transducers and multi-channel systems both for ultrasonic and eddy current testing. Similarly, the concept of simultaneously using

multiple methods of inspection is increasing, for example for the inspection of reactor pressure vessels. On-line and continuous monitoring of plant and equipment inspection is now commonly applied. To cope with the increased use of composite materials high sensitivity test methods such as micro-focus radiography and high frequency ultrasonic testing are now well established.

But, increasing the degree of automation also increases the consequences of error. Therefore, a high degree of automation requires a high degree of monitoring and control. Process integrated NDT must fulfil the requirements of today's industrial production concerning integrate-ability, automation, speed, reliability, and profitability.

References

TÜV Nord – Non-destructive testing of materials and structures (NDT)

American Society for Nondestructive Testing (ASNT)

Wikipedia – Different Testing Procedures

Nondestructive testing & the types of welds: <https://sentin.ai/en>

10 Annexure -1: Codes and Standards

The Tables below lists the major codes from AWS, ASME and API. It is not a comprehensive list of every single code that these organizations have published, but it does provide a quick overview of the codes related to welding. If you require a complete and up-to-date list of any or all their codes, please visit their website.

American Welding Society (AWS)

AWS D1.1	This code contains the requirements for fabricating and erecting welded steel structures. This code applies to steels with a thickness of 1/8 inch (3.2mm) or more. When this code is specified in a contract, most of the provisions are mandatory. Optional provisions and examples are shown in an annex included within this code.
AWS D1.2	This is the Structural Welding Code-Aluminum. The welding requirements are applicable to any type of welded aluminum alloy structure. This code is appropriate for use in fabrication of supporting structures and appurtenances. It is not intended to supplant codes developed for use in specialized fabrication such as the ASME Boiler and Pressure Vessel Code, aerospace codes, or military codes.
AWS D1.3	This is the Structural Welding Code-Sheet Steel. This code covers the arc welding of structural steel sheet/strip steels including cold formed members which are equal to or less than 3/16 inch (.188 in./4.8mm) in nominal thickness. Three weld types unique to sheet steel, arc spot, arc seam, and arc plug welds are included in this code.
AWS D1.4	This is the Structural Welding Code-Reinforcing Steel. This code shall apply to the welding of reinforcing steel to reinforcing steel and of reinforcing steel to carbon or low-alloy structural steel. This code shall be used in conjunction with the prescribed general building code specifications and is applicable to all welding of reinforcing steel using the processes listed in Section 1.4 and performed as a part of reinforced concrete construction. When reinforcing steel is welded to

	structural steel, the provisions of AWS D1.1 shall apply to the structural steel component.
AWS D1.5	This is the Bridge Welding Code. This code covers welding fabrication requirements applicable to welded highway bridges. It is to be used in conjunction with the AASHTO Standard Specification for Highway Bridges or the AASHTO LRFD Bridge Design Specifications. This code is not intended to be used for the following: steels with a minimum specified yield strength greater than 690 MPa (100ksi), pressure vessels or pressure piping, base metals other than carbon or low alloy steels, or structures composed of structural tubing.
AWS D1.6	Structural Welding Code-Stainless Steel. This code covers welding requirements applicable to stainless steel weldments subject to design stress. It shall be used in conjunction with any complementary code or specification for the design or construction of stainless-steel weldments.
AWS D3.5-93R	Guide for Steel Hull Welding. This guide is referenced in many contract specifications for building vessels from barges to tugboats.
AWS D3.6M	Specification for Under-Water Welding.
AWS D3.7	Guide for Aluminum Hull Welding. Similar to the Steel Hull Welding Guide, but with a special emphasis on the unique properties of aluminum.
AWS D8.8-97	Specification for Automotive and Light Truck Weld Quality: Arc Welding.
AWS D14.1	Specification for Welding Earth Moving and Construction Equipment. Applies to all structural welds used in the manufacture of earthmoving and construction equipment. This specification reflects the welding practices employed by manufacturers within the industry and

	incorporates various methods which have been proven successful by individual manufacturers.
AWS D14.5	Specification for Welding Presses and Press Components. The purpose of this specification is to establish minimum acceptable requirements for weld joint design and the fabrication by welding of presses and press components and is not intended to apply to material feed mechanisms and tooling. It shall also apply to the modification or repair by welding of new or existing presses or press components.

American Society of Mechanical Engineers

ASME Section I	Requirements for Power boilers. Part PW lists the Requirements for Boilers Fabricated By Welding. The rules in Part PW are applicable to boilers and component parts thereof, including piping constructed under the provisions of this Section that are fabricated by welding and shall be used in conjunction with the general requirements of Part PG as well as with the specific requirements in the applicable Parts of this Section that pertain to the type of boiler under consideration.
ASME Section II	Material Specifications-4 Subparts (A, B, C, D). Subpart A-Ferrous Material Specifications. Subpart B-Non-Ferrous Material Specifications-Materials. Subpart C Specifications for Welding Rods, Electrodes, and Filler Metals. Subpart D- Properties-divided into three subparts- 1 Stress Tables. 2 Physical Properties Tables. 3 Charts and Tables for Determining Shell Thickness of Components Under External Pressure.
ASME Section III	Nuclear-There are Three Subdivisions- Division 1-Rules For Construction of Nuclear Facility Components. Subsection NB lists Class 1 Components. Subsection NC lists Class 2 Components.

	<p>Subsection ND lists Class 3 Components. Subsection NE lists Class MC Components. Subsection NF covers Supports. Subsection NG deals with Core Support Structures. Subsection NH covers Class 1 Components in Elevated Temperature Service. Division 2-Code For Concrete Reactor Vessels and Containment. Division 3-Containment Systems for Storage and Transport Packaging of Spent Nuclear Fuel and High-Level Radioactive Material and Waste.</p>
ASME Section IV	<p>Rules For Construction of Heating Boilers. The rules to Part HG apply to steam heating boilers, hot water heating boilers, hot water supply boilers, and appurtenances thereto. They shall be used in conjunction with the specific requirements of Parts HF and HC whichever is applicable. The forward provides the basis for these rules. Part HG is not intended to apply to potable water heaters except as provided for in Part HLW.</p>
ASME Section V	<p>Non-Destructive Examination. Unless otherwise specified by the referencing Code Section, or other referencing documents, this Section of the Code contains requirements and methods for nondestructive examination which are Code requirements to the extent they are specifically referenced and required by other Code Sections. These nondestructive examination methods are intended to detect surface and internal discontinuities in materials, welds, and fabricated parts and components. They include radiographic examination, ultrasonic examination, liquid penetrant examination, magnetic particle examination, eddy current examination, visual examination, leak testing, and acoustic emission examination.</p>
ASME Section VI	<p>Recommended Rules For the Care and Operation of Heating Boilers. This is divided into nine subsections. 1-General, covers scope and terminology. 2-Types of Boilers. 3-Accessories and</p>

	Installation. 4-Fuels. 5-Fuel Burning Equipment and Fuel Burning Controls. 6-Boiler Room Facilities. 7-Operation, Maintenance, and Repair-Steam Boilers. 8-Operation, Maintenance, and Repair-Hot Water Boilers and Hot Water Heating Boilers. 9-Water Treatment
ASME Section VII	Recommended Guidelines for the Care of Power Boilers
ASME Section VIII	Pressure Vessel and Tank Code. This is divided into three subdivisions. Division 1-Subsection A is general pressure vessel information. Subsection B covers the Requirements Pertaining to Methods of Fabrication of Pressure Vessels. Subsection C lists the Requirements Pertaining to Classes of Materials. Division 2 covers Alternative Rules for Construction of Pressure Vessels. Division 3 lists Alternative Rules for Construction of High-Pressure Boilers.
ASME Section IX	Welding and Brazing Qualifications. This section covers the requirements for Weld Procedure Specifications (WPS), Procedure Qualification Records (PQR), and certification requirements for tackers, welders, welding operators, and brazing personnel.
ASME Section X	Fiber-Reinforced Plastic Pressure Vessels.
ASME Section XI	Rules for In-service Inspection of Nuclear Power Plant Components.
ASME B31.1	Power Piping This Code prescribes requirements for the design, materials, fabrication, erection, test, and inspection of power and auxiliary service piping systems for electrical generation stations, industrial and institutional plants, central and district heating plants, and district heating systems, except as limited by para. 100.1.3. These systems are not limited by plant or property lines unless they are specifically limited by para. 100.1. Piping as used in this Code includes pipe, flanges, bolting, gaskets, valves, relief

	<p>devices, fittings, and the pressure containing portions of other piping components. It also includes hangers and supports and other equipment items necessary to prevent overstressing the pressure containing components. The users of this Code are advised that in some area's legislation may establish governmental jurisdiction over the subject matter covered in this Code. However, any such legal requirement shall not relieve the owner of his inspection responsibilities specified in para. 136.1.</p>
ASME B31.2	<p>Fuel Gas Piping-Material, This Code covers the design, fabrication, installation, and testing of piping systems for fuel gases such as natural gas, manufactured gas, liquefied petroleum gas-air mixtures above the upper combustible limit, liquefied petroleum gas in the gaseous phase, or a mixture of these gases. Included within the scope of this Code are fuel gas piping systems both in buildings and between buildings, from the outlet of the consumer's meter set assembly (or point of delivery) to and including the first pressure containing valve upstream of the gas utilization device. Piping systems within the scope of this Code include all components such as pipe, valves, fittings, flanges (except inlet and outlet flanges that are a part of equipment or apparatus described in para. 200.1.4), bolting and gaskets. Also included are the pressure containing parts of other components such as expansion joints, strainer and metering devices, and piping supporting fixtures and structural attachments.</p>
ASME B31.3	<p>Process Piping- Rules for the Process Piping Code have been developed considering piping typically found in chemical, petroleum refineries, pharmaceutical, textile, paper, semiconductor, and cryogenic plants, and related processing plants and terminals. This Code prescribes requirements for materials and components, design, fabrication, erection,</p>

	assembly, examination, inspection, and testing of piping. this Code applies to all fluids, including raw, intermediate, and finished chemicals; petroleum products; gas, steam, air, and water; fluidized solids; refrigerants; and cryogenic fluids.
ASME B31.4	Liquid Transportation Systems for Hydrocarbons, Liquid Petroleum Gas, Anhydrous Ammonia, and Alcohol. This Code prescribes requirements for the design, materials, construction, assembly, inspection, and testing of piping transporting liquids such as crude oil, condensate, natural gasoline, natural gas liquids, liquefied petroleum gas, carbon dioxide, liquid alcohol, liquid anhydrous ammonia, and liquid petroleum products between producers' lease facilities, tank farms, natural gas processing plants, refineries, stations, ammonia plants, terminals (marine, rail, truck), and other delivery and receiving points. Piping consists of pipe, flanges, bolting, gaskets, valves, relief devices, fittings, and the pressure containing parts of other piping components. It also includes hangers and supports, and other equipment items necessary to prevent overstressing the pressure containing parts.
ASME B31.5	Piping Refrigeration-This Code prescribes requirements for the materials, design, fabrication, assembly, erection, test, and inspection of refrigerant and secondary coolant piping for temperatures as low as -320°F except as specifically excluded.
ASME B31.8	Gas Transmission and Distribution-This code covers the design, fabrication, installation, inspection, testing and safety aspects of operation and maintenance of gas transmission and distribution systems, including gas pipelines, gas compressor stations, gas metering and regulation stations, gas mains, and service lines up to the outlet of the customer's meter set assembly. Included within this Code are gas transmission and gathering pipelines, including appurtenances, that are installed offshore for the purpose of

	transporting gas from production facilities to onshore locations. Much more is also covered in this code.
ASME B31.9	Building Services Piping-This Code Section has rules for the piping in industrial, institutional, commercial, and public buildings, and multi-unit residences which does not require the range of sizes, pressures, and temperatures covered in B31.1.
ASME B31.11	Slurry Transportation Piping Systems-This code prescribes minimum requirements for the design, materials, construction, assembly, inspection, testing, operation, and maintenance of piping transporting aqueous slurries of non-hazardous materials, such as coal, mineral ore, concentrates, and other solid material, between a slurry processing plant or terminal, and a receiving plant or terminal.

American Petroleum Institute

API 570	Piping Inspection Code- This code covers the inspection, repair, alteration, and rerating of in-service piping systems. API 570 was developed for the petroleum refining and chemical process industries but may be used, where practical, for any piping system. It is intended for use by organizations that maintain or have access to an authorized inspection agency, a repair organization, and technically qualified piping engineers, inspectors, and examiners, all as defined in Section 3.
API 620	This code lists the requirements for Design and Construction of Large, Welded, Low Pressure Tanks. This code applies to carbon steel above ground, including flat bottom tanks, that have a single vertical axis of revolution. The tanks described in this standard are designed for metal temperatures not greater than 250°F and with pressures in their gas or vapor spaces not more than 15 psi.

API 650	Welded Steel Tanks for Oil Storage. This standard covers material, design, fabrication, erection, and testing requirements for vertical, cylindrical, aboveground, closed and open-top, welded steel storage tanks in various sizes and capacities for internal pressures approximating atmospheric pressure (internal pressure not exceeding the weight of the roof plates), but a higher internal pressure is permitted when additional requirements are met. This standard applies only to tanks whose entire bottom is uniformly supported and to tanks in nonrefrigerated service that have a maximum operating temperature of 90°C (200°F).
API 653	Tank Inspection, Repair, Alteration, and Reconstruction. This standard covers carbon and low alloy steel tanks built to API Standard 650 and its predecessor API Specification 12C. API 653 provides minimum requirements for maintaining the integrity of welded or riveted, atmospheric pressure, aboveground storage tanks after they have been placed in service. It covers the maintenance inspection, repair, alteration, relocation, and reconstruction of such tanks. The scope of this publication is limited to the tank foundation, bottom, shell, structure, roof, attached appurtenances, and nozzles to the face of the first flange, first threaded joint, or first welding-end connection. This standard employs the principles of API 650; however, storage tank owner/operators may apply this standard to any steel tank constructed in accordance with a tank specification.
API 1104	Welding of Pipelines and Related Facilities. This standard covers the gas and arc welding of butt, fillet, and socket welds in carbon and low-alloy steel piping used in the compression, pumping, and transmission of crude petroleum, petroleum products, fuel gases, carbon dioxide, and nitrogen, and where applicable, covers welding on distribution systems. It applies to both new construction

	<p>and in-service welding. The welding may be done by a shielded metal-arc welding, submerged arc welding, gas tungsten-arc welding, gas metal-arc welding, flux-cored arc welding, plasma arc welding, oxyacetylene welding, or flash butt welding process or by a combination of these processes using a manual, semi-automatic, or automatic welding technique or a combination of these techniques, The welds may be produced by position or roll welding or by a combination of position and roll welding. This standard also covers the procedures for radiographic, magnetic particle, liquid penetrant, and ultrasonic testing as well as the acceptance standards to be applied to production welds tested to destruction or inspected by radiographic, magnetic particle, liquid penetrant, ultrasonic, and visual testing methods.</p>
--	---